

MODIFIED SPOUTED BEDS

— WITH THE GAS OUTLET LOCATED IN THE SIDE WALL SURROUNDING THE ANNULAR DENSE BED —

Hirotsugu HATTORI and Kunihiko TAKEDA

*Dept. of Chem. Eng., Faculty of Textile Sci. and Tech.,
Shinshu Univ., Ueda, Japan*

INTRODUCTION

The advantages of the spouted bed technique invented by K. B. MATHUR and P. E. GISHLER¹ are well known. However, in the commonly used spouted beds, large amount of the gas passes through the spout without percolating through the annular dense phase, as shown in Fig. 1. MATHUR et al. say in

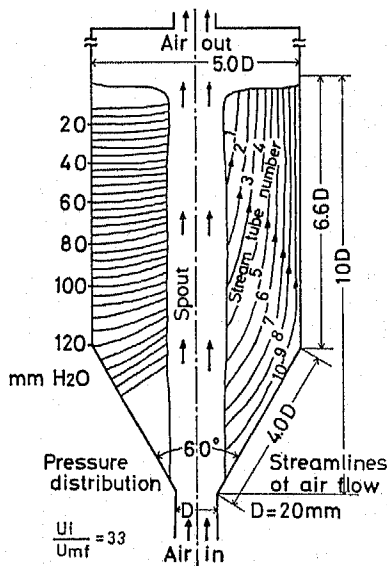

Pressure distribution and air streamlines in the annulus

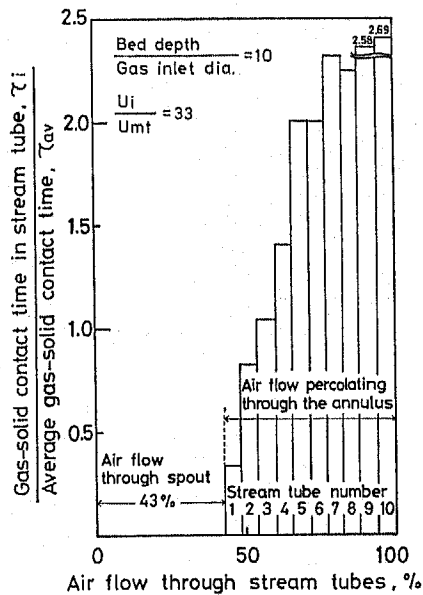

Variation of gas-solid contact time in the annulus

Fig. 1 A commonly used spouted bed

their recent paper²⁾ that the spouted bed, in common with a fluidized bed, is always a less efficient system for gas conversion than a fixed bed, since agitation of solid particles is achieved at the expense of inefficient conversion of gas passing through the spout in the spouted bed.

The gas-solid contact in the spouted bed must be carried out mainly by the gas percolation through the annular dense phase. Therefore, if all of the gas is made to percolate through the annular dense phase, the spouted bed would be more efficient. Paying attention to this point, we have made an attempt to improve the spouted bed in such a way that all of the gas percolates through the annulus. The results have been published already in Kagaku Kogaku Ronbunshu, vol. 1, No. 2, p 149 (1975)³⁾ and Kagaku Kogaku Ronbunshu, vol. 2, No. 5, p 507 (1976)⁴⁾. The former describes the hydrodynamic examination and the latter the estimation of gas conversion. In the present paper, we mention only the important ones of these results.

MODIFIED SPOUTED BED

So as to prevent the gas flow from leaving the apparatus without percolating through the annular dense bed, the upper part of the vessel was closed and the circular gas outlet openings were located side by side in the side wall

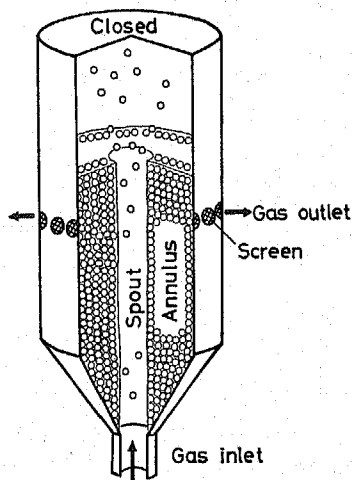

Fig. 2 Schematic diagram of a modified spouted bed

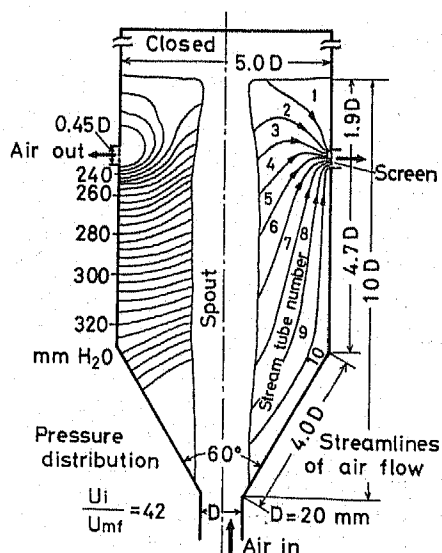

Fig. 3 Pressure distribution and air streamlines in the annulus of a modified spouted bed

surrounding the annular dense bed. Fine screen was put on each of the gas outlet openings.

The diagrams of the modified spouted beds are shown in **Figs. 2 and 3**. The sufficient gas flow to maintain a stable spout is introduced from the gas inlet opening at the bottom of the vessel. Part of the gas goes into the annular space and the rest rises upward through the spout. The gas in the spout, having reached some above the bed level, reverses its direction, passes through the annular dense bed, and leaves the vessel through the gas outlet openings in the side wall. Thus all of the gas necessarily passes through the annular dense bed before it leaves the vessel.

On the other hand, the motion of the solid particles in the modified spouted bed is not remarkably different from that of a commonly used spouted bed. Similarly, in the modified spouted bed, the particles are carried upward by the gas in the central spout and move uniformly downward in the annular space surrounding the spout.

Therefore, it may be said that the performance of the spouted bed as the gas-solid contact system is improved, while the main advantages of the spouted bed, such as isothermicity due to agitation of solids, are still retained.

FURTHER IMPROVEMENT OF THE SPOUTED BED

By the modification of the gas outlet position, we can make all of the gas pass through the annular dense phase. However, good spouting is achieved

only over a narrow range of the gas inlet diameter, the gas flow rate and the bed height. In addition, there is considerable variation of the gas-solid contact time caused by the difference of the gas flow path length in the annular dense bed as shown in **Fig. 4**.

In order to obviate these defects, we have made another attempt to use a double walled type which has been used in a fluidized bed by ISHIDA and SHIRAI⁵⁾, in combination with the side-outlet spouting operation. That is to say, inner cylinder was put vertically surrounding the central spout in a side-outlet type spouted

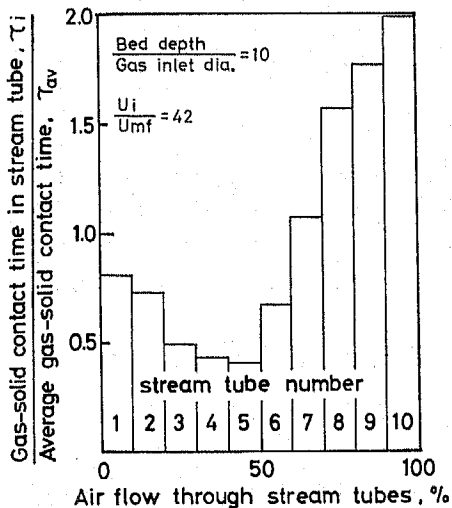
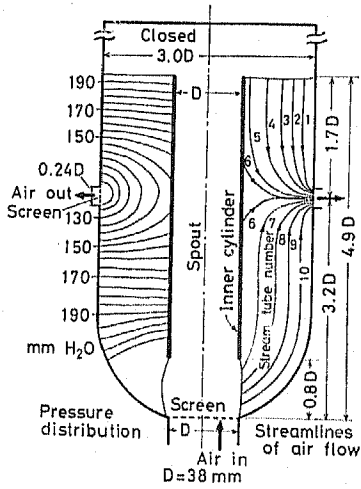
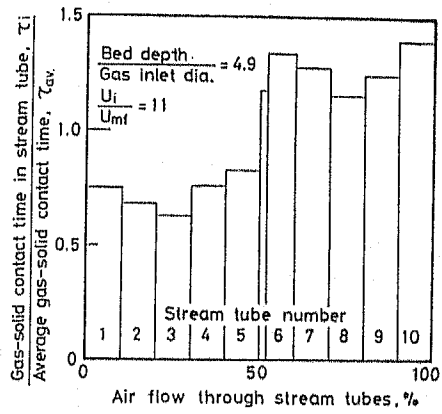

Fig. 4 Variation of gas-solid contact time in the annulus of a modified spouted bed



Pressure distribution and air streamlines in the annulus



Variation of gas-solid contact time in the annulus

Fig. 5 A modified spouted bed, double-walled type

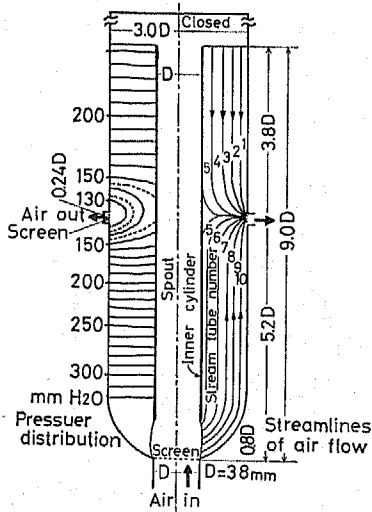

Pressure distribution and air streamlines in the annulus

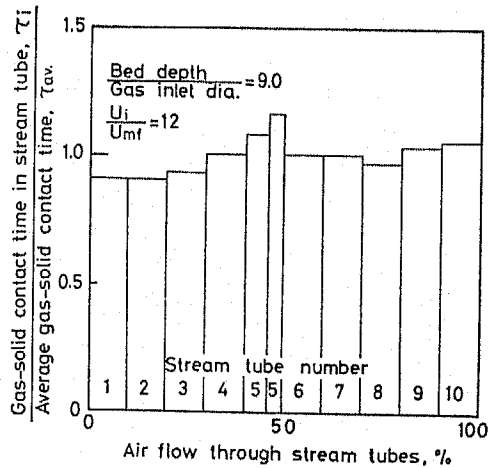

Variation of gas-solid contact time in the annulus

Fig. 6 A modified spouted bed, double-walled type

bed. Consequently the various defects of the spouted bed have been obviated. Diagrams of typical double-walled spouted beds are shown in Figs. 5 and 6.

In the double-walled spouted bed, the annular solid bed never collapses

because the inner cylinder supports the solids in the annular space. Accordingly, the gas flow rate and the shape of the vessel can be changed over a wide range without decreasing the stability of the spouted bed. Both the gas-solid contact time and the time required for the solids to pass through the annular space can be varied over a relatively wide range by the adjustment of the total gas flow rate or the change of the shape of the vessel. *

Furthermore in the double-walled spouted bed, there is no cross flow of the gas from the spout to the annulus or the solids from the annulus to the spout. Then the variation of the gas-solid contact time in the annulus which depends on the difference of the gas flow path length in the annulus is very small. In addition, all of the particles, starting at various radii on the top surface of the annulus, reach the bottom of the bed after staying in the spout about the same time. Time required for the solids to pass through the annular space is considerably uniform. **

DETERMINATION OF THE GAS FLOW PATH IN THE ANNULUS

To determine the gas flow path in the annular space in the spouted bed, following experiments have been made by the use of the air at room temperature and the spherical glass beads. Average properties of glass beads are shown in **Table 1**. Pressure distribution in the annulus was measured using a half sectional column cut by a vertical plane. Many small openings (0.3 mm in diameter) are arranged with separations of 5-10 mm on the flat wall of the half sectional column. Under the steady state operation conditions, the static pressure at each small opening was measured with a water-air U-tube or a micromanometer. It should be noted that the pressure distribution in the annulus can not be exactly measured by the insertion of a pressure probe into the annulus.

A relationship between pressure gradient and air velocity was predetermined empirically by the use of the packed bed in which the void fraction was maintained at the same value as in the annulus of the spouted bed. The void fraction is almost the same anywhere in the annulus of the spouted bed. By the aid of this relation, the velocities and directions of gas flow at various positions can be obtained from the pressure distribution data. The pressure

Table 1

Properties of solids (glass beads)	
Average diameter	1.8mm
Specific gravity	2.5
Angle of repose	29°
Minimum fluidizing velocity	1.1m/sec

* Kagaku Kogaku Ronbunshu, vol. 1, No. 2, p153, Fig. 9

** Kagaku Kogaku Ronbunshu, vol. 1, No. 2, p152, Fig. 7

distribution is expressed using the isobaric lines as shown on the left half of Fig. 3. The other half of Fig. 3 illustrates the streamlines of air percolating through the annular space. Streamlines are drawn in such a way that they intersect perpendicularly the isobaric lines. The volumetric flow rate of gas, passing through each stream tube between two adjacent streamlines is one-tenth of the gas percolating through the annulus. The gas-solid contact time in each stream tube is calculated by dividing the volume of each stream tube by the volumetric flow rate of the gas passing through the stream tube. The variation of gas-solid contact time obtained in this way is shown in Fig. 4. The stream tube numbers in Fig. 4 correspond to those in Fig. 3. As is evident from Fig. 3, all of the gas necessarily percolates through the annular dense phase in the modified spouted bed.

CALCULATION OF THE GAS CONVERSION

In order to compare the performance of the modified spouted bed as a reactor with that of the commonly used top-outlet type one, the calculation of the gas conversion was carried out based on the picture of the gas streamlines in the annular space of each type of the spouted beds.

The two-region model of a spouted-bed catalytic reactor²⁾ suggested by MATHUR et al. is worth noting as a new approach for predicting the chemical conversion for a spouted bed reactor. Their method, however, is not based on the experimentally obtained gas flow pattern in the annular space, so that it can not be applied to investigating how the improvement of gas flow pattern affects the performance of a spouted bed reactor. We propose a quick and convenient calculation based on the observed gas flow pattern. The present calculation does not require any empirical equation, for instance, an equation for the fractional gas flow rate in the annulus. This greatly simplifies the calculation. Analogous to the case of MATHUR et al., we consider the simple case of a first order reaction, using porous catalyst particles, with no mass transfer and no diffusional effects. Furthermore, changes in volumetric flux due to changes in molar flux arising from the chemical reactions, as well as due to pressure changes, are ignored in the present calculations. An isothermal reaction is assumed.

It can be considered that the reaction in the spouted bed takes place in the stream tubes connected in parallel as shown in Fig. 7. Assuming plug flow of gas in the spout as well as in the annulus for convenience, the fractional conversion of the reactant leaving the i th stream tube X_i is calculated by the equation

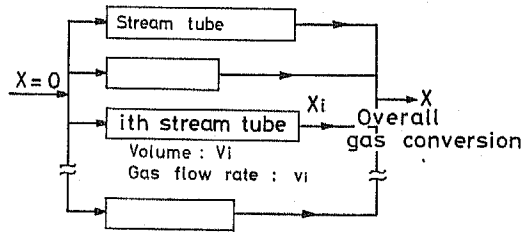

Fig. 7 Parallel stream tubes

$$1 - X_i = \exp[-(1 - \epsilon)K_r\tau_i] \quad (1)$$

where K_r = reaction rate constant based on volume of solids, sec^{-1}

ϵ = void fraction in the stream tube

τ_i = gas-solid contact time in the i th stream tube, sec

$$= \frac{\text{volume of the } i\text{th stream tube } V_i}{\text{volumetric gas flow rate in the } i\text{th stream tube } v_i}$$

We have observed that void fractions are nearly constant everywhere in the annulus. The average values of void fractions in the annulus are slightly different between the commonly used type and the improved one. Observed values of 0.39 for the commonly used one and 0.37 for the improved one are used as the average values of void fractions in the annulus. We applied the average value of 0.95 used by MATHUR et al. over the entire height of the spout.

The unconverted fraction of the reactant leaving the reactor can be then obtained by combining the gas leaving each stream tube. Thus the unconverted fraction of gas leaving the reactor is

$$1 - X = \frac{\sum_{i=1}^n (1 - X_i)v_i}{\sum_{i=1}^n v_i} \quad (2)$$

where X represents the overall fractional conversion which we seek from these calculations, and n is the number of stream tubes. The overall fractional conversion can be calculated by substituting the gas-solid contact time in each stream tube into Eq. (1) and then substituting Eq. (1) into Eq. (2).

THE REACTOR PERFORMANCE

Equally-sized half sectional columns of the top-outlet type and the side-outlet type spouted beds are built to establish the air streamlines in the annuli of the beds as shown in Fig. 8. The ratios of the bed depth to the diameter

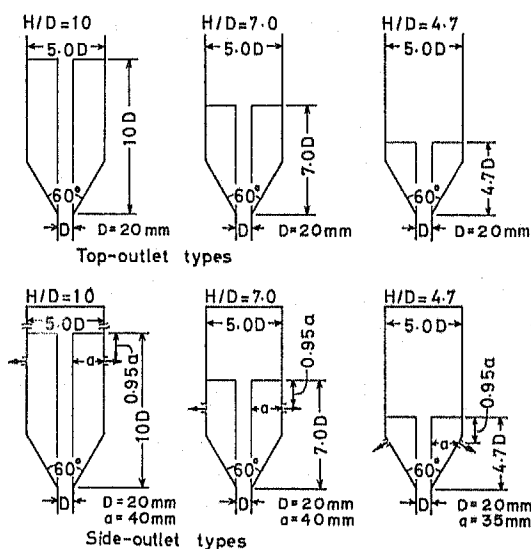
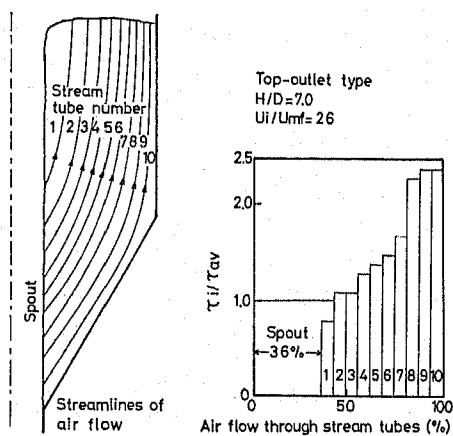
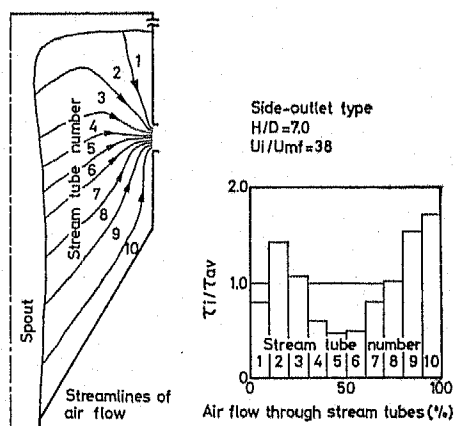

Fig. 8 Schematic diagrams of spouted beds

Fig. 9 Streamlines of air flow in the annulus and variation of gas-solid contact time. Top-outlet type, $H/D = 7.0$ Fig. 10 Streamlines of air flow in the annulus and variation of gas-solid contact time. Side-outlet type, $H/D = 7.0$

of the air inlet, H/D , are 10, 7.0 and 4.7. For these different bed depths, there is no remarkable differences in both the gas flow patterns and the characteristics of the gas conversion curves. The gas streamlines and the variations of gas-solid contact time for the top-outlet and side-outlet types with $H/D = 7.0$ are shown in Figs. 9 and 10.

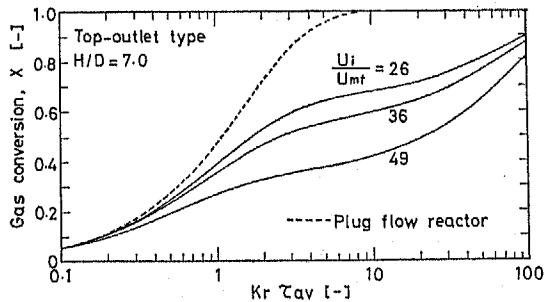

Fig. 11 Effect of gas flow rates on gas conversion for the top-outlet spouted bed

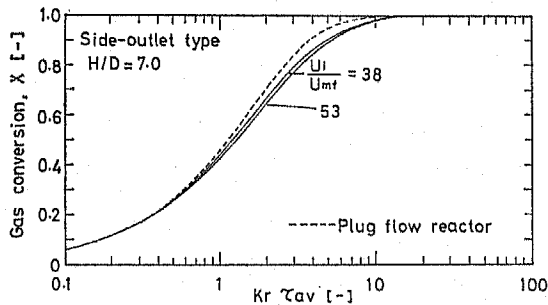

Fig. 12 Effect of gas flow rates on gas conversion for the side-outlet spouted bed

Effect of gas flow rate on gas conversion

Figs. 11 and 12 show the effect of gas flow rates on the overall gas conversion for the top-outlet and side-outlet types. The effect of the gas flow rate on the overall gas conversion remarkably differs between the top-outlet and side-outlet types. For the top-outlet type, the curve moves downward with the increase of the gas flow rate, because the increase in gas flow rate causes an increase in percentage of gas flow rate in the spout. For the side-outlet type, the shape of the gas streamlines is not remarkably affected by the increase in gas flow rate, and the overall gas conversion remains unchanged.

Role of spout and annulus regions in gas conversion

The fractional conversions of the gas leaving the spout and the annulus of the top-outlet type are shown in Fig. 13. The figure also includes the overall gas conversion. As is evident from Fig. 13, the overall gas conversion for the top-outlet type becomes poor because some part of the gas does not go into the annulus and passes only through the spout.

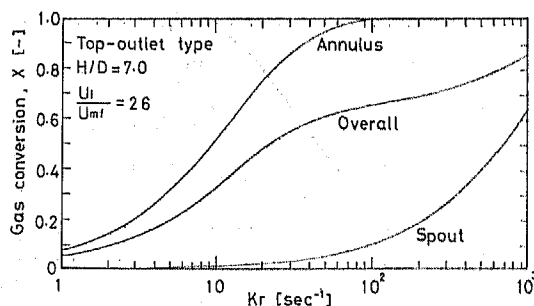

Fig. 13 Fractional conversions of the gas leaving the spout and the annulus

In the annulus, the gas percolates through the void spaces between uniformly moving particles, so the gas flow in each stream tube may closely approximate plug flow. However, in the spout, the complicated and irregular eddying motion of gas, with its large deviation from plug flow, leads to the great difficulty of exact estimation of the gas conversion. The gas-solid contact in the spouted bed is mainly carried out by the gas percolation through the annular dense phase. In the side-outlet type, the gas, having passed through the spout, necessarily percolates through the annulus, so that the overall gas conversion is not substantially influenced by the gas conversion in the spout. This particular feature of the side-outlet type spouted bed makes it possible to easily estimate the conversion of the gas leaving the reactor.

Comparison between top-outlet and side-outlet types

The calculated gas conversions for equally sized top-outlet and side-outlet type spouted beds are presented in Fig. 14 as a function of $K_r \tau_{av}$. The curves were obtained on the basis of the picture of the gas streamlines in the spouted

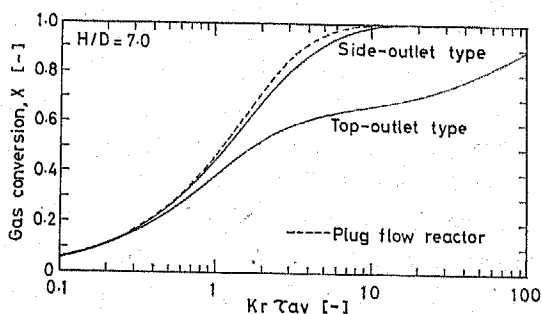

Fig. 14 Comparison of gas conversions between the top-outlet and side-outlet spouted beds, $H/D=7.0$

bed reactor operated nearly at the minimum spoutable gas flow rate*, assuming that the shape of gas streamlines is not altered by changing the gas flow rate. This assumption is not true for the top-outlet type. As mentioned above, the shape of gas streamlines in the top-outlet type is altered by changing the gas flow rate and therefore the gas conversion curve moves downward with increase of the gas flow rate. When the gas flow rate is higher than the minimum spoutable flow rate, the gas conversion for the top-outlet type is in fact lower than the curve in Fig. 14. Therefore the gas conversion as shown in Fig. 14 is overestimated for the top-outlet type with the exception when operated at the minimum gas flow rate. In spite of this overestimation, the side-outlet type gives a higher gas conversion. The gas conversion curve for the fixed bed operation, in which perfect plug flow of gas is assumed, is also shown in the same figure by the broken line. This curve gives the highest gas conversion one can expect for the gas-solid reaction in a flow system. The gas conversion for the side-outlet type approaches to that for the fixed bed reactor with the perfect plug flow.

As we used small columns of 100 mm in diameter, the gas-solid contact time in the reactor is limited to be considerably short. Therefore the rate constant K_r of industrially useful reactions give the values of $K_r\tau_{av}$ in the range of about 0.1-1. When the value of $K_r\tau_{av}$ is in such a range, the extent of gas conversion is not widely different for the top-outlet and side-outlet types. However, when the relatively fast reaction is conducted in the industrially sized unit, the value of $K_r\tau_{av}$ must be much larger and the difference in gas conversion between the top-outlet and side-outlet types becomes larger, as is evident from Fig. 14.

The gas conversion curve for the side-outlet type approaches to that for the plug flow reactor more closely as the ratio of bed depth to air inlet size becomes smaller.

Fig. 15 presents the gas conversion for the double-walled side-outlet type spouted beds as shown in Figs. 5 and 6. There is not any notable differences in gas conversion between side-outlet and double-walled side-outlet types, but the gas conversions for the latter are nearly equal to those of the corresponding fixed bed. This interesting result implies that an approximate value of chemical conversion can be obtained quite simply for the double-walled spouted bed. Without drawing the picture of streamlines in the annulus, we can approximately estimate the chemical conversion by regarding the double-walled spouted bed as the fixed bed reactor which has a uniform gas-solid contact time. It

* Kagaku Kogaku Ronbunshu, vol. 2, No. 5 p510, Fig. 9

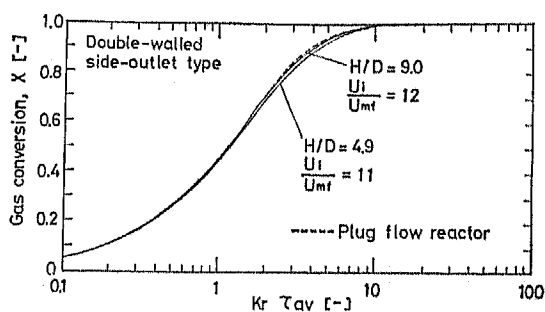

Fig. 15 Gas conversions for the double-walled side-outlet spouted beds

may be considered as one of the most important advantages of the double-walled side-outlet spouted bed.

SUMMARY

The authors have made an attempt to improve the spouted bed from the viewpoint of preventing the gas flow from leaving the apparatus without percolating the annular dense phase. Hydrodynamic examinations showed that the effectiveness of gas-solid contact is much improved. Fractional conversions of the gas leaving the spouted bed reactors were calculated, based on the observed gas streamlines in the annulus. The gas conversion for the commonly used top-outlet type becomes poor because of excessive by-passing of gas through the spout. The side-outlet type gives much higher gas conversion in comparison with the top-outlet type since all of the gas percolates through the annulus. The performance of the side-outlet type approaches to that of the fixed bed reactor which is expected to have the highest value for the gas-solid reaction in a flow system. Especially for the double-walled side-outlet type, the reactor performance is almost the same as the fixed bed reactor.

The new method proposed in the present paper for estimating the performance of the spouted bed reactor uses experimentally obtained gas streamlines, and may be applicable to more complicated reactions.

ACKNOWLEDGEMENT

We would like to express our thanks to Dr. Taiichi SHIBUYA of Shinshu University for his helpful discussions and for reading the manuscript.

Nomenclature

D	= gas inlet diameter	[mm]
H	= bed depth	[mm]
K_r	= reaction rate constant based on volume of solids	[sec ⁻¹]
n	= the number of stream tubes	
U_i	= average air velocity in air inlet	[m/sec]
U_{mf}	= minimum fluidizing air velocity	[m/sec]
V_i	= volume of the i th stream tube	[m ³]
v_i	= volumetric gas flow rate through the i th stream tube	[m ³ /sec]
X	= fractional conversion of reactant leaving the reactor	[-]
X_i	= fractional conversion of reactant leaving the i th stream tube	[-]
ε	= void fraction in stream tube	[-]
τ_{av}	= average gas-solid contact time	[sec]
τ_i	= gas-solid contact time in the i th stream tube	[sec]

LITERATURE CITED

- (1) MATHUR, K. B. and P. E. GISHLER, *A. I. Ch. E. J.*, 1, 157 (1955)
- (2) MATHUR, K. B. and C. J. LIM, *Chem. Eng. Sci.*, 29, 789 (1974)
- (3) TAKEDA, K. and H. HATTORI, *Kagaku Kogaku Ronbunshu*, 1, No. 2, 149 (1975)
- (4) TAKEDA, K. and H. HATTORI, *Kagaku Kogaku Ronbunshu*, 2, No. 5, 507 (1976)
- (5) ISHIDA, M. and T. SHIRAI, Preprint of 38th Annual Meeting of the Soc. of Chem. Engrs., Japan, B-112, Tokyo (1973)