

STUDIES ON THE COMPOUND EYE OF THE BOMBYCID MOTHS***

Nagao KOYAMA***

(Laboratory of Biology and Entomology, Faculty of Textile and Sericulture)

CONTENTS

Introduction

Materials and methods

I. External morphology

1. General form
2. Colouration
3. Surface area
4. Size and number of the facet

II. Internal morphology

1. General structure of the compound eye
2. Structure of the ommatidium
 - a. Cornea
 - b. Crystalline cone
 - c. Iris cell
 - d. Retinular part
 - e. Trachea
 - f. Basal pigment
 - g. Nerve
 - h. Total length of the ommatidium

III. Pigment migration

1. Migration in the different species and races
 - a. *Bombyx mori*
 - b. *Bombyx mandarina*
 - c. *Bombyx mandarina* × *Bombyx mori*
 - d. Discussion
 2. Rhythmic migration
 - a. Glow, an indicator of the pigment migration
 - b. Pigment migration in the natural condition
 - c. Pigment migration in the confined condition
 - d. Discussion
 3. Experiments on the mechanism of the migration
 1. Tying various segments
 2. Spiracle blocking
 3. Decapitation
 4. One side eye covering
- Discussion

IV. Vision

V. Degeneration of the function in the compound eye of the silkworm moth

Summary

Literature cited

-
- * Contribution No. 18 from the Laboratory of Biology and Entomology, the Faculty of Textile and Sericulture, Shinshu University, Ueda, Japan.
** This study was aided by the Scientific Research Expendure of the Department of Education, to which the author expresses his hearty thanks.
*** Lecturer of Shinshu University.

INTRODUCTION

There have been a number of investigations carried out on the compound eyes of *Lepidoptera* (EXNER, 1891: JOHANSEN, 1893: HESSE, 1901 a: DEMOLL, 1909, '10: JOHNAS, 1911: BUGNION & POPOFF, 1914: ELTRINGHAM, 1919: MERKER, 1929: NOWIKOFF, 1931: SUGIYAMA, 1933: COLLINS, 1934: UMBACH, 1934: YAGI, 1938, '50~'53; DAY, 1941), but on those of the Bombycid moths no morphological studies could be expected to be found in addition to the contributions by TOYAMA & ISHIWATA (1899), OKA, A. (1899), IKEDA (1913), SUZUKI, K. (1943), TANAKA (1943), and WOLSKY (1949).

Geneticists and biochemists have treated the Bombycid eye from hereditary point of view on the pigment formation (UDA, 1928, '30, '32: KIKKAWA, 1937~'49: KAWAGUCHI & KON, 1937, '38: MOROHOSHI, 1938, '41: UMEYA, 1938: TAZIMA, 1942: SUZUKI, K. 1943: KATO, M. 1951: KAWASE & ARUGA, 1953).

Those findings are far from our demand to solve the problems of function and physiology of the vision of the Bombycid eye.

It is well-known that the domestic silkworm (*Bombyx mori* LINNÉ) would have been derived from the wild silkworm (*Bombyx mandarina* LEECH)* considering from their morphological and physiological kinships between the both species (SASAKI, 1898: YAGI, 1922: KAWAGUCHI, 1923~'34: KE, 1930 a, b: OMURA, 1939, '41, '50: ISHIHARA, 1941, '43: TAKEDA & TANAKA, 1952: TAKEDA, 1954). If it is certain, the study of modification of the tissue in the domesticated eye would give some interesting problems on the adaptation of vision to the artificial environment.

The author, who has preliminarily reported on the morphology of *B. mori* eye, intends in this paper to give the detailed descriptions on the structure and function of the eye comparing with that of *B. mandarina*.

It is pleasure to record here a debt of acknowledgement to Prof. Nobumasa YAGI for his kindness in supervising the work and reading the original manuscript. Thanks are also due to Prof. Toichi UCHIDA and Prof. Tetsuo INUKAI, Hokkaido University, who gave him very helpful criticisms; to Mr. Senzaburo MIYAGAWA, who sent some materials for the author's use; to Miss Reiko YAMAZAKI and Shigemitsu TANAKA, who assisted him throughout the experiment.

* Various scientific names have been used for the species; *Bombyx fusca* M., *Theophila mandarina* M., *Bombyx* sp. P., *Bombyx mori mandarina*, *Bombyx mandarina* L., *Sericaria mandarina* S., *Bombyx (Theophila) mandarina*. The name used here is due to LEECH'S nomenclature (1888).

MATERIALS AND METHODS

Most of the Bombycid moths used for the experiment were bred from the larvae in the author's laboratory excepting Ringetsu, Daizo, and the red-eye mutant.

The moths of *B. mandarina* were collected from the mulberry farm in the college yard by a light trap, besides those grown from the larval or the pupal stage.

All the materials are shown in the following:

MATERIALS

- 1) *Bombyx mori*

Japanese race	Univoltine (Nichi-11, Fujiiroran)*
	Bivoltine (Nichi-119)
Chinese race	Univoltine (Hekiren, Gominhaku)
	Bivoltine (Amoy-moricaud)
	Tetravoltine (Ringetsu, Daizo)
	Polyvoltine (Binh-dinh)
European race	Univoltine (\bar{O} -15, \bar{O} -19, Zebra)
Red-eye mutant (<i>re</i>)	
Yellow-eye mutant (Tôshokuran, the colour of its egg is orange yellow)	
White-eye mutant (<i>w</i> ₁ , <i>w</i> ₂)	
	Japanese bivoltine × Chinese bivoltine (Nichi-119 × Amoy-moricaud)
- 2) *Bombyx mandarina*
- 3) *Bombyx mandarina* × *Bombyx mori* (*B. mandarina* × Sanminhaku strain)

METHODS

The external observations were performed on the materials fixed by 35% formalin and 70% alcohol mixture, referring the living one.

For the histological observation the compound eyes were sectioned with paraffin pertaining to the method as in the followings.

- 1) Fixing, in Sugiyama's (Distillated water 30, 36% alcohol 15, 35% formalin 6, acetic acid (cold) 3), Bouin's or Carnoy's fluid. The latter brought the best result. Softening reagents were not used.
- 2) Inbedding, in m. p. 60~63°C paraffin.
- 3) Staining, with methylene blue, eosin, Delafield's haematoxylin, and Heidenhein's iron haematoxylin.

* The eye of this strain takes a purplish black colouration which can hardly be discriminated from the normal (black) eye strains.

- 4) Depigmentation, with Grenacher's solution. This was not used for the observation of pigment migration.
- 5) Thickness of sectioning, in 5 to 15 μ .

I. EXTERNAL MORPHOLOGY

1) General Form

The side view of a compound eye is ovoidal in shape and crescent from the front. Observing dorsoventrally, its surface curves steeply towards posterior. General form of *B. mori* eye is closely similar to that of *B. mandarina* (Fig. 1).

The size of the eye is correlated with that of the body. The vertical and the horizontal lengths of *B. mori* eye (Chinese univoltine) are 1.40 mm and 1.14 mm respectively. The eye of the hybrid (Japanese bivoltine \times Chinese bivoltine) is larger than that of the parents (Fig. 2). The ratio between the vertical and the horizontal lengths is 1.23 approximately. The radius of the Bombycid moth eyes is shown in Table 1. The curvature was calculated as a part of a circle.

The curvature in the horizontal section is more convex than in the vertical. Minute differences are seen in the

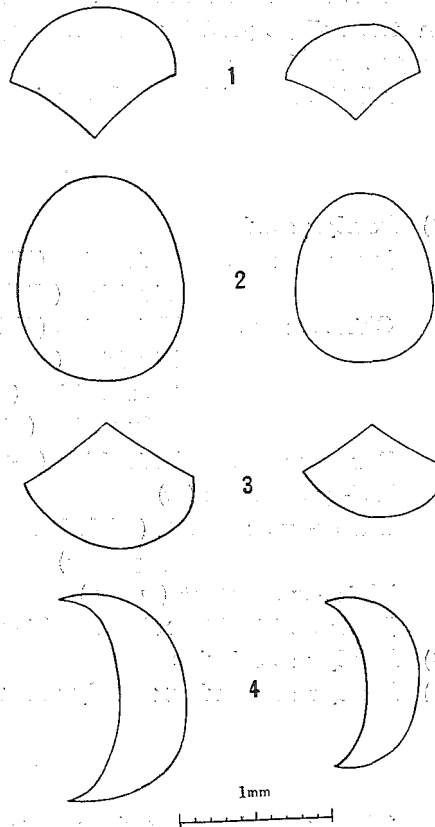

Fig. 1 Shapes of the compound eyes of *Bombyx mori* (left) and *B. mandarina* (right).

1. Dorsal view
2. Lateral view
3. Ventral view
4. Frontal view

Table 1. Radius of the curvature of the compound eye (in 95% reliability)

Species	Vertical (μ)	Horizontal (μ)
<i>Bombyx mori</i>	658 ~ 678	593 ~ 607
<i>Bombyx mandarina</i>	580 ~ 596	558 ~ 570

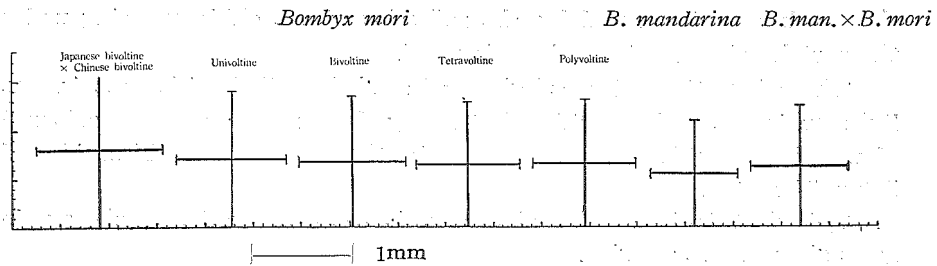

Fig. 2. Vertical and horizontal lengths of the compound eyes.

radial length between the sexes or the strains. The both radii in *B. mandarina* are shorter than those of *B. mori*. In *Chilo simplex* the both radii were about 440μ (YAGI, 1938), showing very convex typeas compared with the Bombycid eyes.

2) Colouration

The colour of the compound eye is generally purplish black in the daytime, and the central pupil can scarcely be identified differing from other moths, while in the night time the pale bluish glow appears in the central part (Fig. 3).

In the red-eye mutant of *B. mori* the colouration is reddish brown in the daytime exposing the glow which is paler than in the night time.

In the yellow-eye mutant the eye is orange yellow when adapted to light, taking grayish black colour at the margin of the eye. When the dark adapted eye is illuminated, the paler glow appears expanding.

The white-eye mutant (Photo 2) shows no change of the colouration at any condition of light or dark. The eye looks like a pearl being bordered by grayish colour as in the case of the yellow-eye. The eye of ω_1 , generally takes white colour and of ω_2 , slight yellowish or pink.

The latter exhibits a glow in the darkness as the yellow-eye does. The fixed eyes of yellow-and white mutants show their own colour as a whole, and

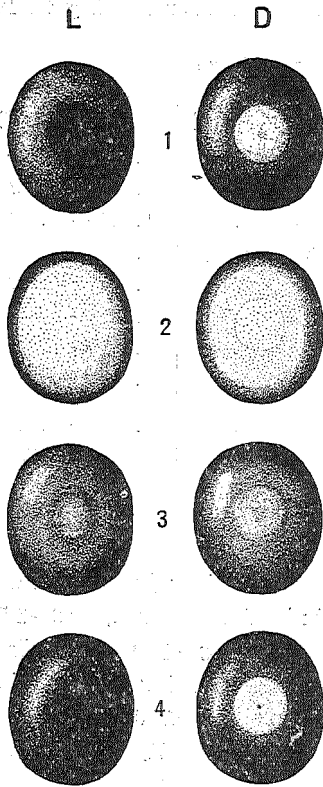

Fig. 3 External appearance of the compound eyes
 L: Light adapted
 D: Dark adapted
 1. Normal eye 2. Yellow eye 3. Red eye (1~3, the eye of *B. mori*) 4. *B. mandarina*

the black margin caused by the reflection of the chitinous ring under the peripheral ommatidium is obliterated.

The colourations of *mandarina* and *mori* show little difference in the light or in the dark condition, but rarely the former exposes a coloured glow of yellowish orange as seen in the eyes of the Noctuid and Saturniid moths.

This fact indicates the difference in the construction of the eye in *B. mori* and *B. mandarina*.

The sexual difference was not recognized in the colouration.

3) Surface Area

The surface area of the compound eye was measured on the enlarged figure by projection using planimeter after treated with 10% KOH solution to make the cornea a plane. It is shown in the following table.

Table 2. Surface area of the compound eye

Species		♀ (mm ²)	♂ (mm ²)
Bombyx mori	1. Japanese univoltine	1.862 ~ 2.122	2.115 ~ 2.429
	2. „ bivoltine	1.792 ~ 2.036	2.253 ~ 2.567
	3. Chinese univoltine	1.575 ~ 1.794	1.627 ~ 1.885
	4. „ bivoltine	1.530 ~ 1.672	1.743 ~ 1.871
	5. „ tetravoltine	1.156 ~ 1.432	1.419 ~ 1.637
	6. „ Polyvoltine	1.366 ~ 1.568	1.671 ~ 1.997
	7. European univoltine	1.686 ~ 1.868	1.843 ~ 2.045
	8. Japanese bivoltine × Chinese bivoltine	2.168 ~ 2.580	2.460 ~ 2.700
<i>Bombyx mandarina</i>		1.222 ~ 1.382	1.384 ~ 1.546
<i>Bombyx mandarina</i> × <i>B. mori</i>		1.341 ~ 1.575	1.547 ~ 1.709

1. Fujiiroran 2. Nichi-119 3. Hekiren 4. Amoy-moricaud 5. Ringetsu
6. Binh-dinh 7. Zebra 8. Nichi-119 × Amoy-moricaud

The area varies according to the races or the strains; Japanese race, 1.90~2.40 mm²: Chin. univol., 1.60~1.80 mm²: Chin. tetravol., 1.20~1.50 mm²: Chin. polyvol., 1.50~1.80 mm²: Europ. race, 1.80~1.90 mm²: Jap. bivol. × Chin. bivol., 2.40~2.60 mm². The surface areas of *B. mandarina* and *B. mandarina* × *B. mori* are 1.30~1.50 mm² and 1.50~1.60 mm² respectively. The surface area of the eye of *Chilo simplex* is 21,996μ² in the female, 26,494μ² in the male, so the Chilo moth eye is no more than one fiftieth of the size of the Bombycid moth eyes.

The significant difference between sample means of surface areas of the eyes was tested by the method of Analysis of Variance (in 5% level of significance) and the results are as follows;

Between sexes; male > female

„ races; Japanese > European > Chinese

„ strains; in Japanese, non-significant: in Chinese, non-

significant between univol. and bivolt.
bivolt. > tetravolt.

„ species; *B. mori* > *B. mandarina* × *B. mori* > *B. mandarina*
Jap. bivolt. × Chin. bivolt. > *B. mandarina* × *B. mori*

The surface area of the male moth eye is wider than that of the female. Such a sexual difference is observed in general moths, on the contrary, in mosquitoes the female eye is wider than the male's (SATO, 1950, '53 a, b).

4) Size and Number of the Facet

The shape of the facets generally takes a regular hexagon (Photo 10) without difference between the sexes or the strains, but irregular shapes are seen at the marginal region of the eyes.

The diameter of the facets in *B. mori* is 27 to 29 μ as shown in Table 3.

Table 3. Size and number of the facet

Species	Subject		Diameter of the facet (μ)		Area of the facet (μ^2)		Number of the facets		Facet number per 1mm ²	
	Sex									
			♀	♂	♀	♂	♀	♂	♀	♂
<i>Bombyx mori</i>	Japanese univoltine	♀	27.7~	27.6~	499~530	495~524	3,692~	4,362~	1,943	1,963
		♂	28.6	28.4			4,009	4,558		
	Japanese bivoltine	♀	27.5~	28.4~	492~512	524~568	3,568~	4,134~	1,992	1,835
		♂	28.1	29.5			4,056	4,710		
	Chinese univoltine	♀	26.1~	27.5~	444~490	493~527	3,368~	3,202~	2,141	1,961
		♂	27.4	28.5			3,848	3,684		
	Chinese bivoltine	♀	27.8~	27.9~	504~524	506~531	2,810~	3,376~	1,883	1,931
		♂	28.4	28.6			3,220	3,602		
	Chinese tetravoltine	♀	26.5~	26.4~	458~517	453~502	2,343~	3,064~	2,050	2,084
		♂	28.2	27.8			2,757	3,302		
Chinese Polyvoltine	♀	27.0~	27.2~	481~510	473~510	2,749~	3,405~	2,012	2,037	
	♂	27.9	28.0			3,155	4,067			
European univoltine	♀	27.9~	28.4~	506~560	524~568	3,163~	3,376~	1,876	1,832	
	♂	29.3	29.6			3,503	3,746			
Japanese bivoltine × Chinese bivoltine	♀	26.1~	26.7~	443~480	463~498	4,705~	5,114~	2,171	2,083	
	♂	27.2	27.7			5,603	5,634			
<i>Bombyx mandarina</i>	♀	23.9~	24.2~	371~393	381~405	3,343~	3,662~	2,618	2,544	
	♂	24.6	25.0			3,475	3,792			
<i>Bombyx mandarina</i> × <i>B. mori</i>	♀	26.7~	27.0~	463~491	474~500	2,811~	3,175~	2,097	2,058	
	♂	27.5	27.8			3,303	3,509			
Reliability in		99%		99%		95%		—		

The strains used are the same as those in Table 2.

The significant difference of the facet diameter between the male and the female is negative except Japanese divoltine, chinese univoltine, Jap. divolt. × Chin. divolt and *B. mandarina*, whose diameters are larger in the male than in the female, and it is recognizable that the more the voltine, the lesser the diameter. The facet diameter of Jap. bivolt. × Chin. bivolt. is reduced than that of the parents; the female 26.6 μ , the male 27.2

μ (mean value). This will be of hybrid rigor, by means of which the area of the eye increases. TOYAMA & ISHIWATA (1899) and IKEDA (1913) reported that the diameter is about 20μ in the lesser length than the author's measurement.

The facet diameter in *B. mandarina* eye is 24.2μ in the female, 24.6μ in the male; in *B. mandarina* × *B. mori*, 27.1μ in the female, 27.4μ in the male; the former is lesser than that of *B. mori*, the latter mediates the parents'. The area of the facet (s) is calculated by the following formula.

$$s = \frac{3\sqrt{3}a^2}{2}$$

Where a is the length of a side of a regular hexagon.

The facet areas of the eyes are about $500\mu^2$ in *B. mori*, $400\mu^2$ in *B. mandarina*, $480\mu^2$ in *B. mandarina* × *B. mori*, as shown in Table 3.

The sexual difference between the areas is not evident in the majority of the strains, while in the minority it is evident.

It seems to be interesting fact that a component unit of tissues differs according to the sexes.

The number of the facet in *B. mori* eye (Table 3) varies as the followings; 3800~4500 in Japanese race, 3000~3500 in Chinese uni- and bivoltines, 2600~3200 in Chinese tetravoltine, 3000~3700 in Chinese polyvoltine, 3300~3600 in European race, 5200~5400 in Jap. bivol. × Chin. bivol. The number varies 3400~3700 in *B. mandarina*, 3100~3300 in *B. mandarina* × *B. mori*; the former species contains more numbers of ommatidium than in *B. mori*, the latter hybrid shows a middle value between the two species.

The facet number per unit area (1 mm^2) of the eyes is 1800~2000 in *B. mori*, 2500~2600 in *B. mandarina* and about 2100 in *B. mandarina* × *B. mori*, without sexual difference (Table 3).

The wild silkworm moth seems to have a capacity to form more acute image than the domestic silkworm does.

The statistical significance of differences in the facet number between the sexes in each species or the interspecies were tested by the preceding method with 5% level of significance and the results are as follows;

male > female, Jap. bivol. (Nichi-119) > Chin. univol. (Hekiren) > Europ. univol. (Zebra) > Chin. polyvol. (Binh-dinh) > Chin. bivol. (Amoy-moricaud) > Chin. tetravol. (Daizo), Jap. univol. > *B. mandarina*, Jap. bivol. > *B. mandarina* × *B. mori* > Chin. tetravol.

II. INTERNAL MORPHOLOGY

1. GENERAL STRUCTURE OF THE COMPOUND EYE

The Bombycid moth eye belongs to the eucone type, on which very many descriptions have been made since the last century (GRENACHER,

1875, '77, 79: EXNER, 1891: PHILLIPS, 1905: HESSE, 1901, '02, '08: KIRCHHOFFER, 1908: BEDAU, 1911: ZIMMERMANN, 1914: OGUMA, 1917: JOHNAS, 1924: NOWIKOFF, 1931: AINO, 1933~'36: SUGIYAMA, 1933: WEBER, 1933: UCHIDA H., 1934: UMBACH, 1934: COLLINS, 1934: YAGI, 1938~'53: DAY, 1941: KOYAMA, 1952 a, b, '53 a, b).

The eye of *B. mori*, of course, develops from the optical disc of the larval lateral ocelli, and in this case WOLSKY (1949) observed two partial discs (Anlagen), one of which lied on the anterior and the other on the posterior.* The margin of the eye touches to the ocular sclerite (SNODGRASS, 1935) which is bordered by the ocular suture. The whole mass of ommatidia is supported by the blackish chitinous broad ring (Photo. 5), which is in role of the suspender of the basement membrane.

The axial section of the eye shows a fan-like shape as in the general case of moth eye, and the angle of this fan will be considered as the visual angle of the one side eye. The visual and the ommatidial angles are shown in the following table.

Table 4. Visual angle of the eyes (in 95% reliability)

Species	Vertical	Horizontal	Ommatidium
<i>B. mori</i>	139 ~ 145°	136 ~ 140°	2.12 ~ 2.26°
<i>B. mandarina</i>	134 ~ 142°	132 ~ 138°	2.03 ~ 2.19°

The calculated visual angles in the vertical and horizontal sections are about 140° in *B. mori* and 135° in *B. mandarina*. The horizontal head angle and the vertical visual one are about 280° and 270° respectively by calculation. The angle subtended by each ommatidium is nearly 2.10° in the Bombycid eye, on the contrary to RAMSAY's description in a dragonfly's eye (30').

2. STRUCTURE OF THE OMMATIDIUM (Fig. 4)

a) Cornea

The outer chitinous lens or cornea is transparent taking a hexagonal shape superficially and concavo-convex in the cross section. The cornea is composed of three layers which are assumed to be correlated to the general layers of cuticle, namely, epicuticle, exocuticle, and endocuticle. The outer layer is about 5 μ , the middle one about 8 μ , the inner one about 2 μ , totally the cornea 15 μ at the center and 10 μ at the edge, in thickness (Table 5). The outer layer is stainable with Heidenhein's iron haematoxylin. The wavy lines are seen in each layer (Fig. 5). The corneal curvature of the inner surface (63~65 μ in *B. mori*: 53 μ in *B.*

* His observation has being confirmed by the author.

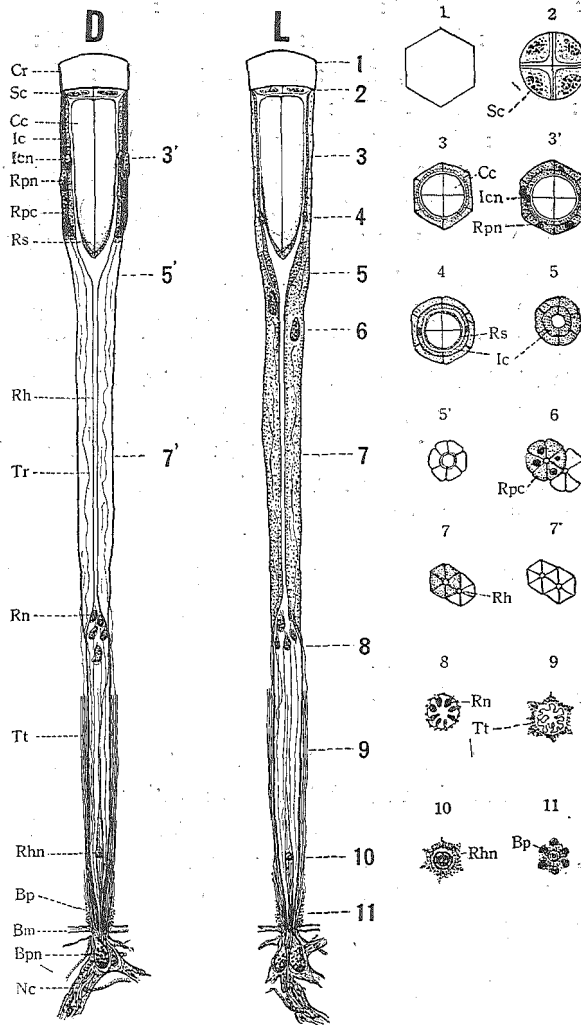

Fig. 4 Longitudinal (left) and cross (right) section of the ommatidium of *B. mori* eye.

D: Dark adapted,

L: Light adapted

Bp: Basal pigment Bpn: Basal pigment cell nucleus Bm: Basement membrane

Cr: Cornea

Cc: Crystalline cone

Ic: Iris cell

Icn: Iris cell nucleus

Nc: Nerve cord

Rs: Reflective substance

Rn: Retinular nucleus

Rpc: Retinular pigment cell

Rh: Rhabdome

Rpn: Retinular pigment cell nucleus

Se: Semper's cell

Tr: Tracheole

Rhn: Rhabdome nucleus

Tt: Tracheal tapetum

mandarina) is lesser than that of the outer one (about 19μ in *B. mori*: 18μ in *B. mandarina*). The refractive index of the lens was measured by Becking & Chamberlin's method (1925) and the focal length (f) was com-

Table 5. Measurement of the cornea (in 99% reliability)

Species	Thickness of the cornea		Radius of the curvature		
	Center (μ)	Edge (μ)	Outer (μ)	Inner (μ)	
<i>Bombyx mori</i>	Jap. univol. (Nichi-17)	15.27~15.33	10.65~10.79	18.56~19.24	64.53~65.07
	bivol. (Nichi-119)	15.57~15.99	10.21~10.47	—	—
	Chin. univol. (Gominhaku)	14.68~14.84	9.37~ 9.47	19.73~20.27	64.70~65.26
	bivol. (Amoy-moricaud)	15.28~15.78	11.44~11.78	—	—
	tetravol. (Ringetsu)	14.11~14.25	9.14~ 9.33	—	—
	polyvol. (Binh-dinh)	10.68~10.88	8.16~ 8.46	18.42~18.78	63.15~63.65
	Europ. univol. (O-15)	15.52~15.68	12.21~12.45	—	—
	White-eye mutant (ω_1)	15.19~15.41	11.18~11.32	—	—
	Jap. bivol. \times Chin bivol.	13.43~13.87	9.43~ 9.87	—	—
	<i>Bombyx mandarina</i>	13.72~13.96	9.63~ 9.83	17.49~17.91	52.67~53.33
<i>Bombyx mandarina</i> \times <i>B. mori</i>	13.09~13.26	9.50~ 9.76	—	—	

puted from the dimensions of the lens by application of the following formula:

$$\frac{1}{f} = (\mu - 1) \left(\frac{1}{r_1} + \frac{1}{r_2} - \frac{(\mu - 1)t}{\mu r_1 r_2} \right)$$

μ = the refractive index of the entire cornea

r_1 and r_2 = the radii of curvature of the external and internal surfaces respectively, and t = the thickness of the lens.

Table 6. Focal length and refractive index of the lenses

Species	Focal length	Refractive index
<i>B. mori</i> (Nichi-11)	43.9 μ	1.350
<i>B. mandarina</i>	37.5	1.374

The focal length of the lens in *B. mori* (43.9 μ) is longer, while the refractive index (1.350) is lesser compared with those (37.5 μ : 1.374) in *B. mandarina*. The image formed behind the cornea is shown in Photo 1.

b) Crystalline part

Under the cornea there lies a layer of Semper's cell* which is com-

* This name was used firstly by CLAPARÈDE (1859). For the cell corresponding to Semper's cell in the Bombycid eye, various names have been given; Corneagen, corneagenous cell, crystalline cell, and hypodermis cell (GRENACHER, 1879; WATASE, 1890; ROSENSTADT, 1896; HESSE, 1901 a; BERNHARDS, 1916; IMMS, 1930; AINO, 1933-'36; SUGIYAMA, 1933; UCHIDA, H., 1934; SNODGRASS, 1935; YAGI, 1938), but what is called corneagen or corneagenous cell consists of two cells, so the author considers that the name of Semper's are more fitted for the cell. Then, the name of crystalline cell must be given to each cell composing the crystalline cone.

posed of four flat cells as in the general ommatidium being attached by the crystalline cone proximally where exists the iris cell sideways. Semper's cell is 1 to 2μ in thickness, and its nucleus is stainable with pigments (Fig. 5, Photo 7, 11).

The crystalline cone takes a bullet-like form and plays an important part in condensing the coming light from the upper corneal lens. The cone body is covered with the crystalline sheath (about 1μ in thickness), and the latter end connects to the distal part of the rhabdome.

The pale coloured granules were found on the surface of the cone body in the sheath when observed by the casting dim light (Photo 37~40). In the Hesperiid eye the same granules was discovered by YAGI (1953), but any descriptions were not recorded on the granules in the Heterocerous eyes. The reflective granules are rich in *B. mandarina*, and much more abundant in the hybrid between the silkworm races than in the pure race of *B. mori*.

The granules are insoluble with alcohol or xylol and stainable with various pigments, being assumed to the dissimilar substance to "weisses Pigment" named by LEYDIG (1868) in the Crustacean's eye, or "Iristapetumzellen" observed by GRENACHER (1879) in the iris pigment cell of the insect eye. Further researches must be done for the question whether this substance is an artifact or not in all the moth eye. Any way it is certain that the substance plays an important photorefective role in the Bombycid moth eyes.

Table 7. Measurement of the crystalline cone (in 99% reliability)

Species	Length of the cone (μ)		Width of the cone (μ)		Thickness of the sheath (in average) (μ)	
	the whole	the body	the whole	the body		
<i>Bombyx mori</i>	Jap. univol. (Nichi-11)	54.03~ 56.70	43.50~ 44.59	17.32~ 17.78	15.31~ 15.59	1.05
	bivol. (Nichi-119)	62.52~ 63.48	55.27~ 55.73	18.30~ 18.00	16.41~ 16.59	0.83
	Chin. univol. (Gominhaku)	66.50~ 68.13	48.68~ 50.32	20.22~ 20.64	18.20~ 18.60	1.07
	bivol. (Amoy-moricaud)	65.64~ 66.12	52.94~ 53.30	16.55~ 16.95	15.00~ 15.27	0.80
	tetravol. (Ringetsu)	53.60~ 55.60	48.79~ 50.23	15.39~ 15.59	12.67~ 12.83	0.87
	polyvol. (Binh-dinh)	53.19~ 54.21	40.55~ 41.05	14.08~ 14.42	12.64~ 12.86	0.75
	Europ. univol. (O-15)	67.68~ 68.56	59.73~ 60.27	18.05~ 18.25	15.77~ 15.91	1.16
	White-eye mutant (w_1)	53.89~ 54.45	43.43~ 43.69	17.83~ 18.17	14.97~ 15.17	1.47
	Jap. bivol. \times Chin bivol.	71.28~ 74.72	52.67~ 55.33	17.35~ 17.65	13.70~ 13.90	1.85
	<i>Bombyx mandarina</i>	54.38~ 54.98	46.11~ 46.35	14.66~ 14.88	13.19~ 13.37	0.75
<i>Bombyx mandarina</i> \times <i>B. mori</i>	70.05~ 70.35	53.92~ 54.08	19.04~ 19.24	14.65~ 14.75	2.22	

Generally the size of the cone is assumed to be about 50μ in the length and 15μ in the width. European race is the largest ($60\mu: 16\mu$), Chinese polyvoltine race is the smallest ($40\mu: 13\mu$), and the other races stand in these two races.

No evident difference on the sizes of the cone between *B. mori* and *B. mandarina* could be recognized.

SUZUKI, K. (1943) reported that the colour of the cone in the black eye of *B. mori* was dark brown, that of the red-eye slight reddish brown, of the pink-eye paler reddish brown, and of the white-eye colourless. According to the author's observation on living materials, all the cone body itself of the moth eyes is colourless. The author experienced sometimes that the colour of the iris pigment penetrates into the cone body in the course of paraffin inbedding of the materials. It is quite probable that the diffusion of pigment through the paraffin will occur in the tissues, and the cone will be stained by the colour of the adjacent

pigment cell.

c) Iris cell

The iris cell (primary pigment cell or distal pigment cell) consists of two cells which contain pigment granules and cover the crystalline cone. The pigment, being reddish brown, distributes homogeneously on the cone surface. The size of the granule in *B. mori* is about 0.63μ , and 0.57μ in *B. mandarina*, both lesser than that of the reticular pigment. The nucleus ($2\sim 4\mu$) is seen in each iris cell (Fig. 4,5, Photo 3,13).

When the moth is putted in the light, the iris pigments migrate downwards to accumulate at the base of the cone leaving one layer of the pigment in thickness, and in the absence of light all the pigments move upwards along the cone surface until the basal end of the cone is opened. Coincidentally the nucleus moves up and down with the migration of the pigment. The reason of holding one layer in thickness of pigment granules is assumed that the light coming from the adjacent cones is obstructed to make the cone have more concentrative function of light. No reflective substances could be observed in the iris cell of the Bombycid eyes differing from the case of the butterflies and mantis.

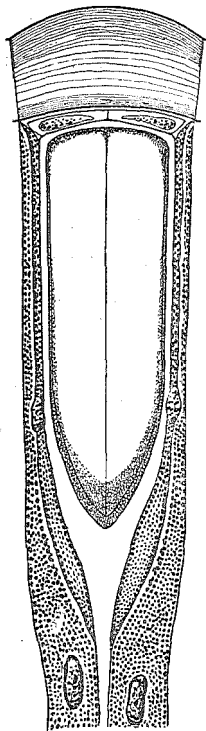

Fig. 5 Longitudinal section of the crystalline part of *B. mori* eye (light adapted)

d) Retinular part

In succession to the cone, the iris cell and the rhabdome are enveloped by the retinular pigment cell which terminates at the top of the rhabdomere, where the retinular nuclei are situated. The retinula is composed of seven to eight cells,* each of which unites compactly making a rod (rhabdome, Photo 8). The retinular nuclei do not move up and down in the retinular part. Such a phenomenon seems to be of interesting fact that has never been observed in the other nocturnal moths (AST, 1920: NOWIKOFF, 1931: SUGIYAMA, 1933: YAGI, 1938). The immobility of the above nuclei is similar to the conduct of the same nuclei in the eye of diurnal *Lepidoptera*. Retinular cells are truly the nerve-end cells as shown by MÜLLER (1829) and SHULTZE (1868), their views having been confirmed by GREINACHER (1879) and HICKSON (1885).

At the basal part of the retinula near the basement membrane, a nucleus (rhabdome nucleus) can be seen and no pigment appears there (Photo 21, 51). The contractile fiber found in the eye of *Coleoptera* by LEYDIG (1934) was not recognizable in the Bombycid eyes. The retinular nuclei of the eye in *B. mandarina* are more easily stained than that in *B. mori* by Heidenhein's iron haematoxylin.

The retinular pigment cell (secondary pigment cell or proximal pigment cell) is composed of six elongated cells (Photo 6, 15, 16). In cross section each cell takes an appearance of a regular triangle surrounding the rhabdome. The nucleus of the retinular pigment cell is about $5\sim 6\mu$ in length lying at the middle part of the crystalline cone when adapted to the dark and moves downwards beneath the cone in the light.

The pigment cell contains densely purplish pigments ($0.65\sim 0.68\mu$) and not any reflective substance.

The colouration of the retinular pigments in the red-eye, the yellow-eye and the white-eye mutants are reddish brown, yellow, and colourless, respectively. The pigment colour in *B. mori* is rather paler than that in *B. mandarina*. When the eye is exposed to light the retinular pigments move downwards and reach to the top of the rhabdomere, while in the dark condition they migrate upwards until the proximal end of the cone is uncovered (Fig 4, Photo 26).

The detailed descriptions on the migration of the pigment will be reviewed in Chapter III.

Quite recently three kinds of pigments i. e. orange, red, and purple were discriminated by KAWASE & ARUGA (1953) in the eyes of the Bom-

* The members who have recognized that the number of each retinula in insect eyes consists of seven to eight cells are: BUGNION & POPOFF (1914), UCHIDA H. (1914), ZIMMERMANN (1914), NOWIKOFF (1931), OGUMA (1917), IMMS (1930), AINO (1933), SUGIYAMA (1933), SNODGRASS (1935), YAGI (1938), WIGGLESWORTH (1950), SATO (1950), etc.

bycid moth, but, as the author has pointed out proceedingly that there are four pigments i. e. iris, retinular, basal and nerve pigments in the Bombycid eyes, he is unable to decide whether any one of three will be contained in any one of these four tissues.

The refractive index of the retinular fluid in *B. mori* eye is 1.3574 (at 20°C).

e) Trachea

The tracheoles from trachea in the head are densely distributed at the proximal part of the rhabdomere, where is called tapetum which reflects the light comes from outside (Photo 9). These tracheoles connect with the tracheal branches underlying the basement membrane. Several tracheoles from the bushes of tracheoles above described extend to the crystalline cone through the interstices of the retinular pigment cells (Photo 54, 56). The tapetal part in *B. mori* and *B. mandarina* generally takes a whitish colouration from outside, while in the latter a certain moth was observed reddish in colour.

BUGNION & POPOFF (1914) named erythrospin and xanthopsin on two coloured substances in the tapetal part in the eye of nocturnal active moth. Quite recently YAGI (1952) discovered in the eye of a Scarabaeid beetle that the tapetal pigments turn to guanin which fluoresces in the night time. Such tapetal substances were not inspected yet in the Bombycid eyes by the author.

Even though the existance of tracheal tapetum is a stated fact in the eyes of nocturnal moth (JOHNAS, 1924: SUGIYAMA, 1933: COLLINS, 1934: UMBACH, 1934: YAGI, 1938: DAY, 1941), HESSE (1901) proposed that a certain species of the Sphingid moth lacks it.

The pretty stout trachea which supplies the air into the individual unit of the compound eye, comes from dorsal tracheal trunk along the posterior part of the periopticon (Photo 23~25) and enters primarily into the compound bundle layer, then it divides in the single bundle one and finally branches out into the tracheoles in each rhabdomere penetrating through the basement membrane.

f) Basal pigment

At the basal part of the tapetum the six pigmental cell can be seen in each ommatidium (Fig. 6, Photo 34~36). In the light or the dark condition the movement of these pigments were hardly be recognized in the eye of *B. mori*, while in that of *B. mandarina* the minute movement was observed as in the

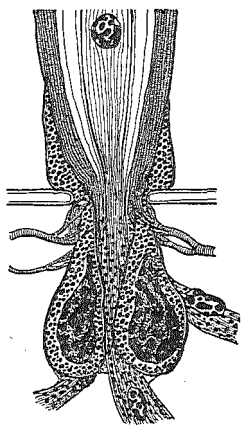

Fig. 6 Semidiagrammatic figure of the basal part of the eye

case of the Crustaceans.

In connection with the basal pigment cell, the large nucleus lies under the basement membrane (Fig. 6; Photo 22). In the moth eye of Japanese strain (Fujiiroran) the basal pigments are abundant in the cell and they connect very often with the reticular pigment cell when adapted to the light (Photo 32, 35). Such phenomenon has never been reported in nocturnal moth eyes.

JOHNAS (1911) has pointed out that there are two main types in the reticular pigment cell, one of which is divided into two parts and the other is continuous. He considers the latter is a primitive one and the former is a type of more evolved. Then it will be said the nuclear pigment cell of Fujiiroran stands in the intermediate type.

g) Nerve

The optic lobe consists of five parts; opticon, internal chiasma, epipticon, external chiasma, and periopticon,* in the both Bombycid moths. The nerve cord starting from the periopticon (Photo 23, 25) enters each rhabdome being divided into the fine fibrils (Fig. 6). The nerve cord is coloured superficially with purplish pigments as much as the surface of the periopticon, in which the assembled nuclei are seen (Photo 24). Between the periopticon and the epipticon the densely pigmented part can be distinguished. This part was called "ocellus remnant" (Photo 25, 41, 43, 45, 55) by IKEDA (1904, '13), but, whether it is a true remnant of ocellus or not must be ascertained by the further research. Neither the grain body nor the giant cell which were found in the larval brain of *B. mori* by KE (1930 b) and KATSUNO (1953) were observed in the optic lobe of the adult.

The nervous pigment of the red-eye is reddish and is paler than that of the reticular pigment.

No pigment can be seen in the nerves of the white-and the yellow-eyes excepting in the ocellus remnant which takes sometimes reddish colouration (Photo 41, 43, 45).

The general structure of the ommatidium in *B. mandarina* is very similar to that in *B. mori* with a little difference in pigment colour, the former's being more darker than the latter's.

h) Total length of the ommatidium

The length of the ommatidium in the Bombycid eyes is about 340μ in Japanese race, $270\sim 300\mu$ in Chinese race, 330μ in European race, 300μ in Jap. bivol. \times Chin. bivol. and *B. mandarina*, 270μ in *B. mandarina* \times *B. mori*. It seems to show the length of Japanese race is the longest,

* The names are due to the description by VIALANS (1885~'87), HICKSON (1885), LUBBOCK (1888), PACKARD (1898), KOPÈC (1922), KOYAMA (1953 b), and YAGI (1953).

European race's the next, Chinese race's the shortest, and that of *B. mandarina* as long as the latter's. It may be of interesting fact that the length in the offspring is reduced from the parents'.

The length of each ommatidial part is shown as proportion to that of the whole ommatidium in Table 8.

Table 8. Length of the ommatidia

Species		Lens	Cone	Retinular part	Rhabdome	Total
<i>Bombyx mori</i>	Jap. univol. (Nichi-11)	15.3 (5)	55.4(16)	167.0(48)	98.4(31)	336.1(100)
	bivol. (Nichi-119)	15.8 (4)	63.0(18)	164.8(47)	108.8(31)	352.4(100)
	Chin. univol. (Gominhaku)	14.8 (5)	67.3(21)	132.0(42)	102.4(32)	316.5(100)
	bivol. (Amoy-moricaud)	15.5 (6)	65.9(24)	91.2(34)	96.0(36)	268.6(100)
	tetravol. (Ringetsu)	14.2 (5)	54.6(19)	122.8(44)	88.4(32)	280.0(100)
	polyvol. (Binh-dinh)	10.8 (4)	53.7(18)	130.4(45)	96.4(33)	291.3(100)
	Europ. univol. (O-15)	15.6 (5)	68.1(21)	146.5(45)	96.0(29)	326.2(100)
	White-eye (<i>w₁</i>)	15.3 (5)	54.2(18)	132.2(45)	92.1(32)	293.8(100)
	Jap. bivol. × Chin. bivol.	13.7 (5)	73.0(24)	122.4(40)	95.2(31)	304.3(100)
<i>B. mandarina</i>		13.8 (5)	54.7(18)	132.0(45)	95.2(32)	295.7(100)
<i>B. mandarina</i> × <i>B. mori</i>		13.2 (5)	70.2(26)	109.6(41)	72.8(28)	265.8(100)

Bracket numbers show the percentage of each length.

The difference of each percentage between the strains is scarcely recognized though the percentage of the retinular part in Amoy-moricaud is lesser than that of the other strains.

III. PIGMENT MIGRATION

1. MIGRATION IN THE DIFFERENT SPECIES AND RACES

In this chapter the migration of the pigment in the Bombycid moth eyes will be described with special reference to that in the retinular pigment.

Five to ten moths were exposed one hour in the light or darkness at the temperature of 25°C. After this treatment the moth eye exhibited a complete adaptation to either of the above conditions.

Process of light adaptation; the dark adapted moths were exposed in the incandescent lamplight of 2kilolux for 2', 5', 10', 20', and 30', at the temperature of 27°C.

Process of dark adaptation; the light adapted individuals were putted in 27°C dark room for 5', 10', 20' and 30'.

The compound eyes in each process were treated for sections.

a. *B. mori*

i) **Japanese race** (Photo 26~31); Nichi-11, Nichi-119, and Fujiiroran were used for pigment observation. The degree of adaptability between the

former two strains differed little, but the rest differed distinctly from the formers'.

The migration in Nichi-11 and Nichi-119 (Photo 26~31)

Light adaptation

- 2'.....The pigment granules move a little downwards, yet the cone end is disclosed.
- 5'.....The pigment granules entirely cover the cone.
- 10'.....The pigment granules move downwards leaving three fourths of the retinula.
- 20'.....The pigment occupies a half of the reticular part.
- 30'.....Minority of the pigment granules arrive at the upper part of the rhabdome, yet majority remain apart 15μ from the rhabdomere.

Dark adaptation

- 5'.....The quantity of the pigment granules around the top of the rhabdomere reduces, still the granules touching to the latter.
- 10'.....The pigment granules move upwards detouching about 48μ from the rhabdomere.
- 20'.....The distance becomes 56μ from the rhabdomere.
- 30'.....The pigment distribution is as same as 5' in the light condition.

According to the above observation, the migration of the pigment in the both strains is almost completed within 30' exposure to the light, but not done in such a short exposure to the darkness.

The migration in Fujiiroran (Fig. 7, Photo 32)

As previously mentioned in Chapter II the eye of Fujiiroran strain has a peculiar type on the distribution of the basal pigment, and the whole of the cone is enveloped by the reticular pigment in the light adaptation. It is certain that its adaptability is lesser than that of the other strains being somewhat similar to the red-eye mutant. The pigment barely reaches the position of a half of the reticular part in 30' illumination and scarcely separates from the rhabdomere in 30' darkness.

ii) **Chinese race:** Hekiren, Amoy-moricaud, Daizo and Binh-dinh were used for the experiments. The pigment migration in Hekiren and in Daizo are very similar to Amoy-moricaud and to Binh-dinh, respectively.

The migration in Hekiren and Amoy-moricaud (Fig. 8)

Light adaptation

- 2'.....The pigment granules move downwards a little until the cone end being scarcely opened.
- 5'.....The cone is entirely enclosed by the pigment granules, the proximal end of which is 25μ apart from the cone end.
- 10'.....The distance between the proximal end of the pigment and

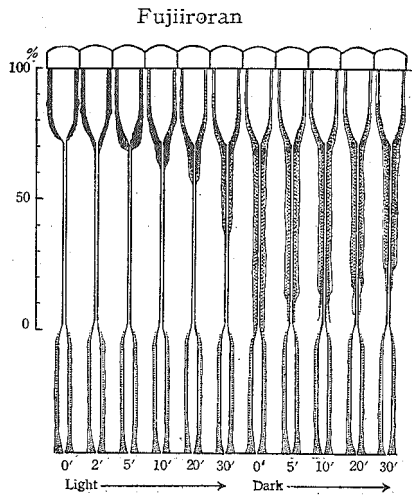

Fig. 7 Pigment migration in the eye of Fujiiroran strain of *B. mori*.

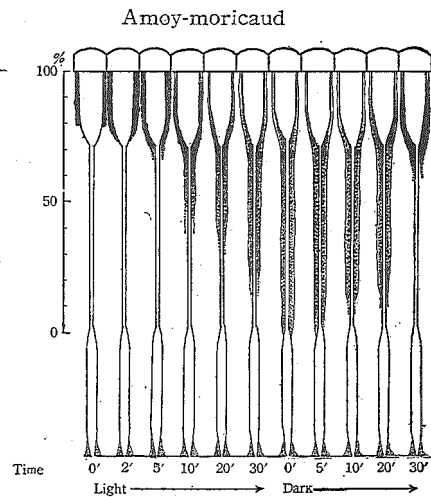

Fig. 8 Pigment migration in the eye of Amoy-moricaud strain of *B. mori*.

the cone end is 45μ which is a half of the reticular part.

20'.....The pigment granules move downwards until the above distance becomes about 60μ .

30'.....The pigment granules do not reach the top of the rhabdomere being apart 25μ .

Dark adaption

5'~10'...The pigment granules scarcely separate from the distal end of the rhabdomere.

20'.....The proximal end of the pigment granules becomes free from the top of the rhabdomere.

30'.....The distance from the proximal end of the pigment granules to the cone end is 25μ .

The migration in Daizo and Binh-dinh

Light adaptation

2'~5'...The pigment granules move downwards in 30μ from the cone end.

10'.....The distance from the proximal part of the pigment to the cone end is 40μ .

20'.....The above distance becomes 60μ .

30'.....The pigment granules almost touch to the top of the rhabdomere.

Dark adaptation

5'.....The pigment granules scarcely separate from the top of the rhabdomere.

10'~20'...Separating completely from the top of the rhabdomere, the

proximal part of the pigment granules reaches the position of a half of the reticular part.

30'.....The cone end is entirely disclosed by the pigment.

The both strains (Chinese polyvoltine) seem to have the higher adaptability to the light and darkness than other strains.

iii) **European race:** Zebra strain was used for the observation.

The migration of the pigment granules in this race is generally slower than that in Japanese and Chinese races having a little similarity to that in Fujiiroran.

iv) **Japanese bivoltine**×**Chinese bivoltine** (Fig. 9)

Light adaptation

2~5'...The pigment granules move downwards until the position of 13μ from the cone end.

10'.....The proximal part of the pigment granules, becoming very slender, reaches the distance about 50μ from the cone end.

20'.....At this time the proximal part of the pigment granules separates a little from the top of the rhabdomere.

30'.....The downward migration of the pigment granules is accomplished entirely.

Dark adaptation

The adaptability to the darkness is very fast, and the pigment granules migrate upwards in 30' exposure until the cone end is opened.

Both upward and downward migration of the pigment are completed with the shortest time in this hybrid as compared with any other strains of *B. mori*.

Japanese bivoltine×Chinese bivoltine

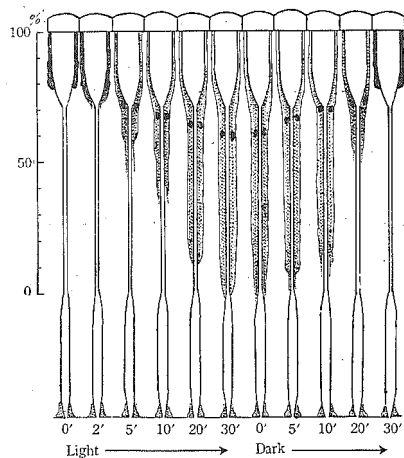

Fig. 9 Pigment migration in the eye of a hybrid (Japanese bivoltine × Chinese bivoltine) of *B. mori*.

Red-eye

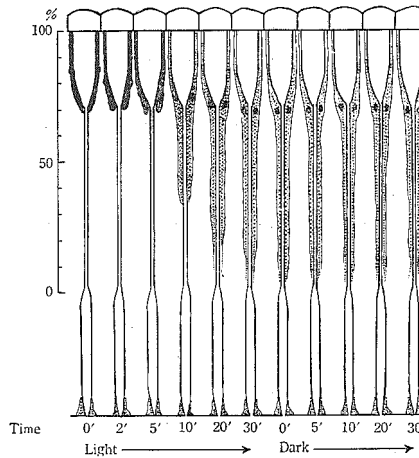

Fig. 10 Pigment migration in the eye of the red-eye mutant of *B. mori*.

v) **Red-eye mutant** (Fig. 10, Photo 41, 45): In the light adaptation the pigment migration of this mutant eye is a little faster than that of Fujiiroran, but is less conspicuous in the dark condition as in Fujiiroran.

vi) **Yellow-eye and white-eye mutants** (Photo 42, 43, 46, 47):

In the white-1 mutant, the colourless granules are hardly seen at the boundary of each crystalline cone, as the observer can recognize the migration of the granules taking the movement of the nucleus as an indicator of this coactor.

The slight pink and the orange yellow eye, both are found very often in the white-2 and in the yellow-eye mutants respectively, can be used for the observation of the pigment migration. In these mutants the adaptation of the eyes to the light and the dark is not accomplished completely, and it is recognized that the coloured granules migrate more faster than the colourless ones which are contained mixed with the coloured ones in the reticular pigment cell as shown Photo 42, 46, 47.

b. Bombyx mandarina (Fig. 11)

The fastest migration of the pigment can be seen in this species either in the light or in the darkness with close similarity to the migration velocity in the hybrid between the races of *B. mori*.

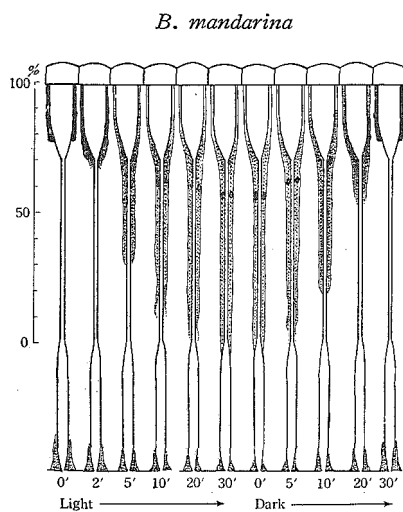

Fig. 11 Pigment migration in the eye of *B. mandarina*.

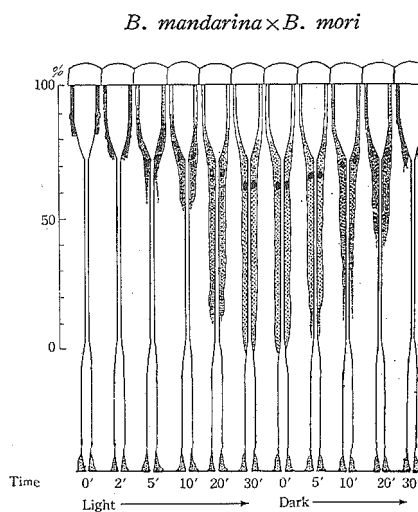

Fig. 12 Pigment migration in the eye of a hybrid between *B. mandarina* and *B. mori*.

c. Bombyx mandarina × *B. mori* (Fig. 12)

The pigment migration in this hybrid appears as same as that in the hybrid between the silkworm races.

d. Discussion

From the above observation, the difference of adaptability to light or

darkness in *B. mori* eye is not so evident between Japanese and Chinese strains, both having higher adaptability than European race, and it may be said that the more the voltine is, the faster the pigment migrates. The migration in the hybrid between the races is accomplished faster than in their parents. This fact seems to be of hybrid vigor as in the case of the ommatidial number of the eye. The compound eye of *B. mandarina* has the highest adaptability to each condition, and it can be recognized to have more evolved function than that of *B. mori*.

Recently the relation between the eye colour and the phototropism has studied in *Drosophila* by KIKKAWA (1943). According to his observation, it has been pointed out that the retinal pigment which is derived from kynurenine group is a kind of photosensible substance, by means of which the phototropism of insects would be brought photochemically, and so the darker the pigment is coloured, the higher the phototropism will be occurred.

The velocity of migration of the pigment in the Bombycid moths seems to be analogous with KIKKAWA's data on the photic sense, because the darker the pigment, the faster the migration.

PARKER (1932) has indicated that there are seven types in compound eyes based on the pigment migration. By his classification *B. mori* belongs to the sixth type (*Astacus* type), while *B. mandarina* belongs to the seventh type as in the case of *Palaemonetes* observed by WELSH (1930 a, b).

No sexual difference could be observed on the migration of the pigment in the above experiments.

2. RHYTHMIC MIGRATION

a) Glow, an indicator of the pigment migration

As stated by LEYDIG (1864), EXNER (1891), DEMOLL (1917), FRIZA (1928), and YAGI (1951), the glow and the pseudopupil which appear in the compound eyes of many insects, are patterns caused by the absorption and reflection of light by the iris or the reticular pigments, and the shapes of patterns depend mainly upon the distribution of these pigments.

Recently YAGI (1951) has fully described on the pseudopupils of butterflies which consist commonly of the single central pseudopupil surrounded by a ring of the six secondary ones.

There are three types of the patterns in moth eyes, in which a single central pupil, seven pupils and non-pupil types are indentified. The Bombycid moth eyes are fairly asserted to belong to the last type, though the central pupil appears faintly. The first type is seen in the wild silkworm moths (*Saturniidae*, KOYAMA, 1952, '53 a) and the second is commonly observed in diurnal active moths.

Generally the pseudopupils belonging to the first or the second types

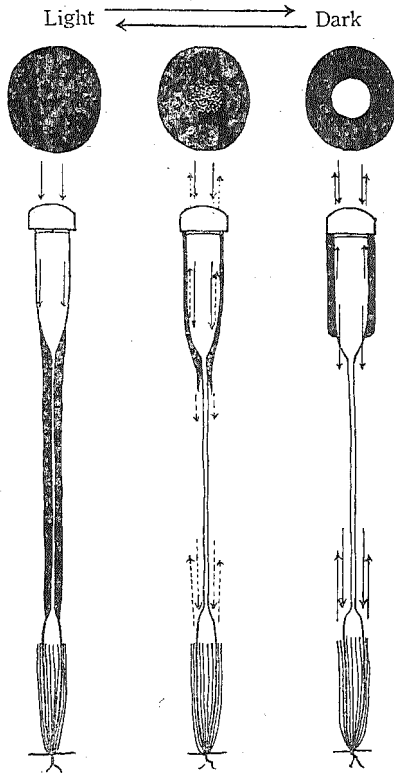

Fig. 13 Retinular pigment migration and external appearance of the eye.

turn into the glow in night. The external appearance of the Bombycid eyes in the light and in its absence are in Fig. 3. The central pupil of the Bombycid eyes scarcely appear in daytime is caused by the fact that the light passing through the cornea is wholly absorbed by the retinular pigments extending to the rhabdomere and also by the iris pigments covering the crystalline cone. In the process from the dark adaptation to the light one, there is a intermediate stage on the shape and the colour of the glow (Fig. 13). So the glow can be used as an indicator of the gradient of pigment migration in the Bombycid moth eyes.

As described in Chapter III the light adaptation of the eye is performed always faster than the dark adaptation, and it can be seen the maximum time necessary for the completion of the both adaptations by the following table.

Presumably from Table 9, it is

Table 9. Time of exposure to make the glow appear in the darkness

Temperature	Sex glow ap- pearance Time	Female			Male		
		Complete	Half	Non	Complete	Half	Non
		16°C	20'	4	5	1	6
	25'	5	5	0	8	2	0
	30'	10	0	0	9	1	0
	35'	10	0	0	10	0	0
22°C	5'	0	5	5	0	5	5
	10'	7	3	0	7	3	0
	15'	10	0	0	10	0	0
26°C	5'	4	5	1	5	4	1
	10'	10	0	0	10	0	0
29°C	5'	6	3	1	7	2	1
	10'	10	0	0	9	1	0
	15'	10	0	0	10	0	0

shown that the appearance of the glow is controlled by the temperature; the higher the latter, the faster the former.

b) Pigment migration in the natural condition

The experiments were carried out during three days of September in 1952 and July in 1953 by using 20 males and females of Chinese univoltine (Hekiren) and of Chinese tetravoltine (Daizo) on *B. mori*, and on *B. mandarina* 10 individuals were used for the experiment regardless the sex (Fig. 14).

Addition to the above experiments the author tried to inspect the relation of the antennae to the adaptation for two light conditions.

But the obliteration of the antennae showed insignificant effect to the reaction of light and dark adaptation.

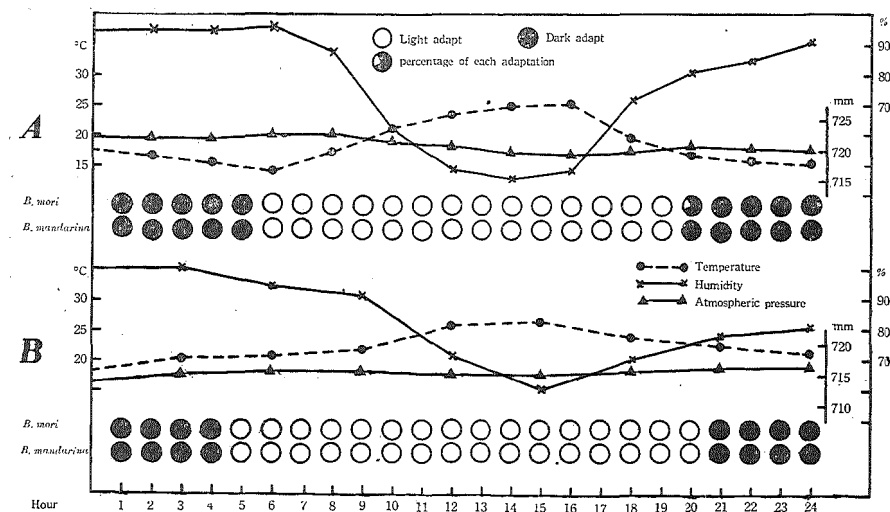

Fig. 14 Rhythmic pigment migration in the Bombycid moth eyes (in the nature).
A: 18, September, 1952 B: 18, July, 1953

The results obtained from the experiments are as follows.

1. The daily alternate rhythmicity of the light and dark adaptation is ascertained.
2. The persistence of the light adapted condition in the eyes is longer in July than in September. This fact will be correlated to the daylength in each season.
3. No sexual difference can be observed relating to the rhythmicity of pigment migration in the eye of *B. mori*.

c) Pigment migration in the constant condition

i) *Bombyx mori*

The previous experiment shown in Fig. 14 A is concerned here to the present experiment, in which the eyes of *B. mori* were exposed continuously to the light (200 lux), and they showed the constant light

adaptation. The other moths putted in the continuous darkness persisted the dark adaptation in the natural environment except the light. While the moths which were confined in the constant condition (the light condition; temperature 20°C, humidity 89%: the dark condition; temperature 25°C, humidity 70%) showed no pigment migration at all.

ii) *Bombyx mandarina*

The same experiment as in the case of *B. mori* were carried out from the 12th to the 14th in August, 1953, keeping the moths continuously in the light or in the darkness with the natural environment. Fig. 15 shows the results of the experiment.

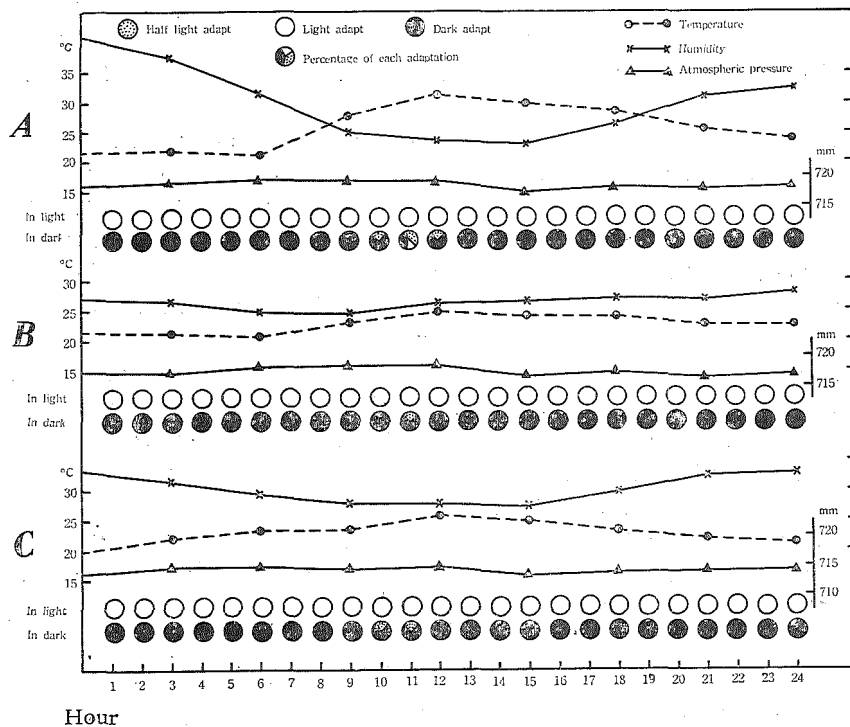

Fig. 15 Rhythmic migration of pigment in *B. mandarina* eye (in continuous light and darkness).

A: 12, August, 1953 B: 13, Aug., '53 C: 14, Aug., '53

It is evidence that no pigment migration could occur in the continuous light condition. On the other hand, in the continuous darkness several moth eyes showed the light or half-light adaptation in short time at forenoon (11 a. m.). The moths, however, putted in the constant environment (temperature 25°C, 22°C, and 33°C: humidity 70%, 80% and 65% ,respectively), are maintained the eye of light or dark adaptation.

From the above experiments it is obvious that the pigment migration of *B. mori* eye is controlled simply by the light, while that of *B. mandarina* is controlled primarily by the light, and secondarily by the other environmental factors, among which the temperature would be most effective.

d) Discussion

A tremendous number of papers have been issued on the rhythmic activity of animals.* According to MORI's opinion it is said that the normal rhythmic activity is maintained under the dual controls, the one by the periodic changes of environmental factors and the other by the rhythmic changes of internal physiological conditions which have more or less intrinsic, hereditary characters. Such rhythmic activities have also been studied in relation to the retinal pigment migration in the Crustacean's eyes (CONGDON, 1907; DEMOLL, 1911; WELSH, 1930~'51; BENNETT, 1932; BENNETT & MERRICK, 1932).

KIESEL (1894) is the first investigator who has discovered the relation between the activity and the pigment migration in moth eye. His observations were reviewed and fully confirmed by DEMOLL (1911, '17). The pigment that took part in this rhythmic response is believed on good ground by these investigators to be the iris pigment. However, the rhythmic migration of pigment in the Bombycid moth eyes undoubtedly happens in the iris and reticular pigments simultaneously belonging to the first type of MORI's classification. In the case of the rhythmic migration of pigment in *B. mori* eye the periodic change of light seems to be the main cause, while that in *B. mandarina* is controlled not only by the light but also by the other environmental factors, though no intrinsic rhythmicity is necessarily concerned.

Accordingly it will be stated that the adaptability of *B. mori* eye to the environment has been reduced functionally further from that of *B. mandarina*, so called ancestor of the former species.

3. EXPERIMENT ON THE MECHANISM OF THE MIGRATION

It is certain, as proceedingly described, the light is one of the most effective environmental factors controlling the pigment migration in *B. mori* eye. However, the question is still remained on the physiological mechanism of its migration in *B. mori* eye.

In the course of this study, the author was struck by the fact that

* BOHN (1906, '09), PIÉRON (1908), PARKER (1917), SZYMANSKI (1920), BELING (1929), WAGNER (1930), WOLF (1930), HOLMQUIST (1931), BÜNNING (1935), GRIFFIN & WELSH (1937), KALMUS (1938 a, b), JOHNSON (1939), YAMANOUCHI (1939), GUNN (1940), PARK (1940), MORI (1943~'51), KLEITMAN (1949), TAKEDA (1950 '54), MORI & MATUTANI (1952), OHSAWA & MORI etc. (1952).

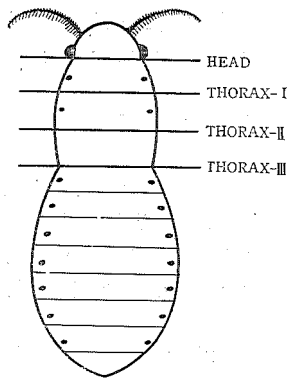

Fig. 16 Showing the position, tied with string in Experiment I.

the imaginal eye develops from the transplanted ocelli on the abdomen of *B. mori* exhibited just like the light adapt structure even though it was kept in the dark room (KOYAMA, 1953b). This fact lead him to the assumption that there are some unknown factors concerning the pigment migration in the absence of the light.

The experiments carried out to solve this question is described in the followings.

Materials: Daizo (the male, 10:
the female, 10)

Condition: Temperature, 22°C:
Humidity, 62%

Expeliment I. Tying various segments

The completely light or dark adapted individuals were tied up one by one in each segment which is shown in Fig. 16 and were putted in the light or the dark condition.

Table 10. The results got in Exepriment I.
(tiding up by the silk string)

The position tied up	No.	External appearance of the eye before tiding up	The conditions given for the moths	Number of individuals of	
				Light adapt	Dark adapt
HEAD	1	Light adapt	Light	20	0
	2	Light "	Dark	20	0
	3	Dark "	Dark	20	0
	4	Dark "	Light	20	0
THORAX-I	1	Light adapt	Light	20	0
	2	Light "	Dark	1	19
	3	Dark "	Dark	3	17
	4	Dark "	Light	20	0
THORAX-II	1	Light adapt	Light	20	0
	2	Light "	Dark	0	20
	3	Dark "	Dark	0	20
	4	Dark "	Light	20	0
THORAX-III	1	Light adapt	Light	20	0
	2	Light "	Dark	0	20
	3	Dark "	Dark	0	20
	4	Dark "	Light	20	0
CONTROL (normal)	1	Light adapt	Light	10	0
	2	Light "	Dark	0	10
	3	Dark "	Dark	0	10
	4	Dark "	Light	10	0

The results obtained in this experiment are as follows (see Table 10):

- 1) The eye always shows the light adaptation in the presence of the light.
- 2) No difference is seen in each adaptation between CONTROL and THORAX-I, THORAX-II or THORAX-III.
- 3) All the individuals in HEAD-No. 2 and -No. 3 show the light adaptation in spite of the absence of the light. This will be a noticeable fact to prove that a certain conductor controlling the pigment migration exists on the first thoracic segment in the darkness.
- 4) In HEAD-No. 2, all individuals loosed the string adapted the darkness. If any humoral or hormone substance had related to the migration, the eyes should persist the light adaptation, but in fact they immediately adapt to the darkness.

Experiment II. Spiracle blocking

There exist nine pair of spiracles on the imaginal body of *B. mori*, and in the thorax two pair of ones lie on the first and second segments (IKEDA, 1913; HARIZUKA, 1947, see Fig. 16). The author carried out the blocking experiment of the various spiracles in the moth to see the relation between the air supply and the pigment migration.

Table 11. The blocking experiment of the spiracles on the moth body

Blocking treatment for	No.	External appearance of the eye before blocking	The conditions given for the moths	Number of in dividuals of	
				Light adapt	Dark adapt
All spiracles on both sides (I)	1	Light adapt	Light	20	0
	2	Light "	Dark	17	3
	3	Dark "	Dark	20	0
	4	Dark "	Light	20	0
All spiracles on both sides of the abdomen (II)	1	Light adapt	Light	20	0
	2	Light "	Dark	0	20
	3	Dark "	Dark	0	20
	4	Dark "	Light	20	0
Two pair of spiracles on the thorax after having tied up THORAX-III(III)	1	Light adapt	Light	20	0
	2	Light "	Dark	5	15
	3	Dark "	Dark	2	18
	4	Dark "	Light	20	0
One side spiracles on the thorax after having tied up THORAX-III (IV)	1	Light adapt	Light	20	0
	2	Light "	Dark	4	16
	3	Dark "	Dark	4	16
	4	Dark "	Light	20	0
CONTROL (normal)	1	Light adapt	Light	20	0
	2	Light "	Dark	0	20
	3	Dark "	Dark	0	20
	4	Dark "	Light	20	0

From this experiment the following results were got (see Table 11).

- 1) The downward migration of the pigment is always observed in the presence of the light as same as in Experiment I.
- 2) The results in (I), (II) and (III)* equal to those in Expt. I-HEAD. So, it is believed too much to say that the downward migration of the pigment depends upon the air supply through the thoracic spiracles.
- 3) In (IV)-No. 2 (light→dark), it was observed that the eye on the side, which the spiracle had not been blocked, adapted to the light faster than that on the blocked side, and in (IV)-No. 4 (dark→light) the former eye adapted to the darkness faster than the latter one. The above belief (in the topic 2) has become more reasonable by this experiment.

Experiment III. Decapitation

The completely light or dark adapted moths were decapitated and were confined in each condition before the tissues had died. In this ex-

Table 12. The decapitating experiment

No.	External appearance of the eye before decapitating	The conditions given for the moth	Number of individuals of	
			Light adapt	Dark adapt
1	Light adapt	Light	20	0
2	Light "	Dark	7	13
3	Dark "	Dark	10	10
4	Dark "	Light	20	0
Normal	Light adapt	Light	10	0
	Light "	Dark	0	10
	Dark "	Dark	0	10
	Dark "	Light	10	0

periment the author obtained the results as shown in the following topics (see Table 12).

- 1) The eyes always adapt the light when they are illuminated.
- 2) Regardless decapitation, about a half of the materials show the dark adapted eye when putted in the darkness (No.2 and No.3). This fact differs from the result in Head tying experiment (Expt. I, HEAD-no. 2, 3) in which all the moths adapted to the light.
- 3) In No.2 and No.3, if the opening of wound caused by decapitation was blocked by paraffin, all the eyes became soon the light adapted appearance as in the case of Head-tying. It is probable to presume that in decapitation the tracheae in a half number of treated individuals were not squelched to supply the air, while those in the

*. That a few individuals show the light adaptation is considered to be caused by some bad treatments.

rest could not supply the air by squelching.

- 4) Accordingly the upward migration of the pigment in this case will not be dependent upon the effect of the nervous excitement by the decapitation and also upon the blood supply from the vessel.

Experiment IV. One side eye covering

When one eye in a moth covered so as to be inaccessible to light and the other was illuminated, no light adaptation could be seen in the latter eye which adapted to the darkness.

Discussion

There are two opinions concerning the controlling mechanism of retinal pigment migration in the compound eye of *Arthropoda*; the one* is supporting that the retinal nerve plays mainly a controlling role of the pigment migration, and the other** is explained by what the nerve has no relation to the migration, which is controlled by humoral or hormone substances.

In the latter opinion it is said the migration is brought by the hormone which is secreted from the sinus gland, though KNOWLES (1950) pointed out the pigment migration in *Crustacea* may be controlled not only by the sinus hormone but also by the nervous one. On the other hand, after CONGDON (1907) found that the pigment migration in *Crustacea* was controlled by the temperature too, there has been presented another view that the daily metabolic rhythmicity in the body has relation to the migratory mechanism of pigment (MENKE, 1911; BENNETT & MERRICK, 1932; HENKES, 1952) as in the case of activity in other animals. However, the physiological mechanism on the pigment migration in moth eyes has never fully been clarified.

From the above several experiments the downward migration of the pigment in *B. mori* eye is inevitably done in the presence of light even if the air supply to the tissues are not shutted off. On the contrary, the upward migration of the pigment has changed to the downward one in the absence of light when the tissues are shutted from the air (Table 10, 11). So, in the darkness the air supply will be a controlling factor for the downward migration of the pigment.

If any common humoral and hormone controls were existent in *B. mori* eye, the downward migration should be happened in the cases of Expt. I, Result 4 (in this case the pigment migrated upwards), Expt. IV (in this case the covered eye persisted the dark adaptation), and in the

* DEMOLL (1910, '11, '17), TROJAN (1913), BENNETT (1924).

** VON FRISH (1908), PARKER (1897, 1932), CASTLE (1927), HOGBEN & SLOME (1931), WELSH (1932~'51), KLEINHOLZ (1934, '36, '48, '49 b), HANSTRÖM (1937 a, b, '39), NAGANO (1947, '50, '52), SMITH (1948).

compound eye developed from the transplanted lateral ocelli of the larva (the upward migration was to be occurred in the dark condition, KOYAMA, 1953). But eitherward migration of the pigment could not be observed.

Thus, in *B. mori* eye the existence of the hormone control by common blood circulation will be questionable in regard to the pigment migration but the further investigations are requested for the author to prove this question.

IV. VISION

1) Visual field

The visual field of the Bombyx moth is extraordinarily large as has been shown in the previous chapter concerning the visual head angle of horizontal and of vertical, adding the radiating open angle of both eyes. The author tried to take the image of a square paper (100cm²) by using a microscope through a peice of peeled cornea of a moth eye (Japanese bivoltine×Chinease bivoltine), and got the image of object and numbers of lens which participates to the image formation at various distances as shown in Table 13. The area of image perception at the cornea is

Table 13. Number of facets formed the image of object (10 cm square paper) and length of object

Distance from cornea to object (cm)	Number of facet formed image		One side length of square (μ)
	Horizontal	Vertical	
23	13	26	18.3
30	12	23	17.0
44	11	22	13.6
68	9	16	8.5
80	7	14	7.0
103	3	6	3.8
133	2	3	1.0
150	1	1	0.5

elliptic corresponding to the oval shape of the eye, and it becomes smaller inversely to the distance whereas the size of the image decreases.

Taking the value of the author's experiment into consideration the maximum distance of recognition in *B. mori* eye when exposed to see the object (10cm square) will be 150cm. This value is about the same with that of the experiment by EXNER (1891), though he did not mention the size of object.

The constancy of the size of an image in the eye could be retained if the size of the object would be increased proportionally by receding in

the distance.

The resolving power of an ommatidium, on which BARLOW (1952) has quite recently reported on the apposition eye is estimated as 2cm beyond the corneal lens, seeing two points apart in 1mm.

2) Image formation

Since EXNER (1891) demonstrated the image formation in the compound eye of *Lampyris*, his interpretation on the formation of the superposition image in the eye of nocturnal insects has been predominated. The allied method was applied to take a photograph of an image in the eye of lateral ocelli of *Isia isabella* by DETHIER (1943, '53) and in the compound eye of *Hesperiidae* by YAGI (1953). In the latter case the images from numerous corneal lenses were not superposed but juxtaposed at the top of the rhabdomere.

In *B. mori* eye the clear image is formed in the retinula separately beneath the pointed end of the cone within the distance of 15~20 μ (about 1/7 of the retinular length) as shown in Photo 1, 4 and away from it the image fades. If the image would be superposed in one point as EXNER interpretes, it must be caught somewhere in the retina in crossing rays of light, but in the eye of *B. mori* the image perception was not exemplified as in the case of the previous author.

According to the author's research on the formation of image in *B. mori* eye, the light from the cone falls straightwards by the checking function of the retinular pigment which rejects the biased rays coming sidewise between the top of rhabdomere and the end of the cone. Then the image is focused in each unit ommatidium like a case of butterflies' eye compositing totally a mosaic image.

V. DEGENERATION OF THE FUNCTION IN THE COMPOUND EYE OF THE SILKWORM MOTH

There have been many investigations reported on the comparative morphology and physiology between *B. mori* and *B. mandarina* (SASAKI, 1898: YAGI, 1922: KAWAGUCHI, 1923 a, b: KE, 1930 a, b: OMURA, 1939, '41, '50: ISHIHARA, 1943: TAKEDA & TANAKA, 1952), among which KUWANA (1936) found out the degeneration of tissue in the silkworm moth.

In this paper the auther has pointed out several times on the degeneration of functional parts relating to the optical system comparing with those of *B. mandarina*.

The following table will show the summary of differences between the domesticated and the wild silkworm.

Table 14. Comparison of the eye of *B. mori* moth with that of *B. mandarina*

No.	Subjects	<i>B. mori</i>	<i>B. mandarina</i>
1	Colouration of glow	Pale	Pale, rarely orange yellow
2	Number of facet per 1mm ²	1,800~2,000	2,500~2,600
3	Reflective substance on the cone surface	Poor	Abundant
4	Retinular nucleus	Non-migratory, Stainable	Non-migratory, Easily stainable
5	Pigment granule colour of ratinula and optic nerve	Purple	Dark purple
6	Retinular pigment	Migratory	More migratory
7	Basal pigment	Non migratory	A little migratory
8	Rhythmic migration of pigment in darkness	Non	A little

It will be worth to notice that the wild silkworm moth, as shown in the last colum, has higher adaptability to daily periodic change of environment than the domesticated one.

SUMMARY

In this paper the structure and function of the compound eye in the Bombycid moth are described with special reference to the differences between the domestic (*Bombyx mori* LINNÉ) and the wild (*Bombyx mandarina* LEECH) silkworm moths. It is summarized as followings.

EXTERNAL MORPHOLOGY

- 1) Shape and Size. The side view of the compound eyes is ovoidal in shape and crescent from the front in either sex. The ventral and the horizontal widths of the eye are 1.40 mm and 1.14 mm in *B. mori*, 1.10 mm and 0.88 mm in *B. mandarina* respectively, and the ratio between both is about 1.23. The vertical and horizontal radii of the curvature are about 670 μ and 600 μ in *B. mori*, about 590 μ and 565 μ in *B. mandarina*; the latter is more convex than the former. The surface area measured on the eyes is as following; *B. mori*, the largest 2.40~2.60 mm² (Japanese bivoltine \times Chinese bivoltine), the middle 1.90~2.40 mm² (Japanese race), the smallest 1.20~1.50 mm² (Chinese tetravoltine): *B. mandarina*, 1.30~1.50 mm²: *B. mandarina* \times

- B. mori*, 1.50~1.60 mm. The area is much wider in the male than in the female.
- 2) Colouration. The colour of the compound eye is generally purplish black in the daytime and the central pupil can scarcely be identified, while in the night the pale bluish glow appears brilliantly. The red eye, the yellow eye and the white eye in *B. mori* mutants does hardly expose the glow. No sexual difference is recognized in the colouration.
 - 3) Size and Number of the Facet. The shape of the facets generally take a regular hexagon. The diameter of a facet is 27~29 μ in *B. mori*, about 24 μ in *B. mandarina*, and about 27 μ in *B. mandarina* \times *B. mori*; the facet area 500 μ^2 , 400 μ^2 , 480 μ^2 , respectively. The facet number varies as follows; *B. mori*, the most 5200~5400 (Japanese bivoltine \times Chinese bivoltine), the middle 3300~3600 (European race), the least 2600~3200 (Chinese tetravoltine): *B. mandarina*, 3400~3700: *B. mandarina* \times *B. mori*, 3100~3300. It is more numerous in the male than in the female. The facet number per unit area (1 mm²) is 1800~2000 in *B. mori*, 2500~2600 in *B. mandarina*, and about 2100 in *B. mandarina* \times *B. mori*, without sexual difference.

INTERNAL MORPHOLOGY

- 1) General Structure of the Compound Eye. The axial section of the eye shows a fan-like shape, in which the visual angle is 140° in *B. mori* and about 135° in *B. mandarina*, both horizontal head angle and vertical visual one are about 280° in the former and 270° in the latter. The angle subtended by each ommatidium is nearly 2.10°.
- 2) Structure of the Ommatidium. The outer layer of the ommatidium is the cornea of concavo-convex lens. The quarter-circular four cells of Semper's lie under the former, the crystalline cone is situated beneath them. Two iris cells enclose the cone with six reticular pigment cells which, enveloping the rhabdome in their center, terminate at the top of the rhabdomere. The rhabdomere surrounded by tracheal tapetum touches to the basement membrane, where the basal pigment can be seen.
- 3) Cornea. It is composed of three chitinous layer, the outer layer is about 5 μ , the middle one about 8 μ , the inner one about 2 μ , totally the cornea 15 μ at the center and 10 μ at the edge in *B. mori*. The radii of curvature of the inner surface and the outer one are 63~65 μ and 19 μ in *B. mori*, 53 μ and 18 μ in *B. mandarina*, respectively; the latter's curvature is more convex than the former's. The focal length of the lens in *B. mori* (43.9 μ) is longer, while the refractive index (1.350) is lesser, than those in *B. mandarina* (37.5 μ : 1.375).
- 4) Crystalline Part. Semper's cell about 2 μ in thickness being com-

- posed of four flatted cells. The crystalline cone takes a bullet-like form, the size of which is generally about 50μ in the length and 15μ in the width in *B. mori*: European race is the largest (60μ : 16μ), Chinese polyvoltine is the smallest (40μ : 13μ), and *B. mandarina* (46μ : 13μ) and *B. mandarina* × *B. mari* (54μ : 15μ) stand in above two strains. The reflective granules covering the cone surface in the sheath are rich in *B. mandarina*, and much more abundant in the hybrid between the silkworm races than in the pure race of *B. mori*.
- 5) Iris Cell. It consist of two cells which contain the reddish brown granules, the size of which is about 0.63μ in *B. mori* and 0.57μ in *B. mandarina*. The nucleus ($2\sim 4 \mu$) is seen in each cell.
 - 6) Retinular Part. The retinular cell is composed of seven to eight cells, each of which unites compactly making a rhabdome and reaches the basement membrane. The retinular nuclei which are immobile either in light or darkness are situated at the distal end of the rhabdomere. The retinular pigment cell consists of six elongated cells, in which the purplish granules ($0.65\sim 0.68 \mu$) are contained except the yellow eye and the white one whose granules are colourless. The pigment colour in *B. mori* is rather paler than in *B. mandarina*.
 - 7) Trachea. Tracheoles make the tapetum, from which several tracheoles extend to the crystalline cone through the interstices of the retinular pigment cells. The tapetal part in *B. mori* and *B. mandarina* takes a whitish colouration from outside, while in the latter a certain moth is observed reddish in colour.
 - 8) Basal Pigment. It is seen at the basal part of the tapetum. In the eye of a strain (Fujiiroran) of *B. mori*, the pigment cell connects very often with the retinular pigment cell in the light adaptation. Such a fact has never been recorded in regard to nocturnal moth eyes.
 - 9) Nerve. The optic lobe consists of five parts; opticon, internal chiasma, epipticon, external chiasma, and periopticon, in the Bombycid moth. The nerve cord and the periopticon are coloured superficially with purplish pigments. The remnant of ocellus is seen between the periopticon and the epipticon. The colouration of the nerve is looked to be some relation to that of the retinular pigment.
 - 10) Total Length of the Ommatidium. It varies as follows; *B. mori*, the longest $340\sim 350 \mu$ (Japanese race), the medium $300\sim 320 \mu$ (Chinese univoltine, European race, Japanese bivoltine × Chinese bivoltine), the shortest $270\sim 290 \mu$ (Chinese bi-, tetra- and poly-voltine): *B. mandarina*, about 300μ ; *B. mandarina* × *B. mori*, about 270μ . The percentage of length of each part is approximately 5% (lens), 20% (cone), 45% (retinular part), and 30% (Rhabdomere).

PIGMENT MIGRATION

- 1) The iris and the retinular pigments migrate up and down in light and darkness on the contrary to the basal pigment which is immobile in all the strains of *B. mori*, but it is movable in *B. mandarina*.
- 2) The nuclei of the retinal pigment cells move as the migration of the pigment granules, while the retinular nuclei which generally move in nocturnal moth eyes, are immobile.
- 3) The downward pigment migration is accomplished faster, without sexual difference, than the upward one which is very slow in the eye colour mutants of *B. mori*.
- 4) Even in the white-eye the migration of the granules (colourless) takes place. It is confirmed by means of taking the nucleus as an indicator of the movement.
- 5) The adaptability of the eye to light and darkness is much higher in *B. mandarina* than in *B. mori*, in which the hybrid between the races is the fastest.
- 6) It is ascertained that the more the voltine or the darker the pigment is, the faster the migration is performed. This fact coinciding with the relation between eye colour and phototropism in *Drosophila* observed by KIKKAWA.
- 7) According to PARKER's classification on the pigment migration, *B. mori* belongs to the sixth type (Astacus type), while *B. mandarina* belongs to the seventh type (Palaemon type).
- 8) It is recognizable that the higher the temperature is, the faster the glow appears.
- 9) The daily alternate rhythmicity of the light and dark adaptation is ascertained without sexual difference.
- 10) The pigment migration of *B. mori* is controlled simply by the light, while that of *B. mandarina* is controlled primarily by the light, and secondarily by the other environmental factors, among which the temperature would be most effective, but in the latter species no intrinsic rhythmicity is necessarily concerned.
- 11) The downward migration of the pigment in *B. mori* eye is inevitably occurred not only in the presence of light but also in the absence of light when the tissues of the compound eye are shutted from the air supply. So, in the darkness the air supply to the tissues seems to be related to the downward migration of the pigment in *B. mori*.
- 12) The existance of the hormonal control by common blood circulation is questionable in regard to the pigment migration of *B. mori* eye.

VISION

- 1) From facet number per unit area of the eye the wild silkworm moth

seems to have a capacity to form more acute image than the domestic silkworm does.

- 2) The area of image perception at the cornea is elliptic, and the maximum distance of recognition in *B. mori* eye, when exposed to see 10 cm square paper, will be 150 cm.
- 3) The resolving power of a facet is estimated as 2 cm beyond the corneal lens, seeing two points apart in 1 mm.
- 4) *B. mori* eye, as in the Hesperiid eye, forms the juxtaposition image in the retinula beneath the pointed end of the cone within the distance of 15~20 μ .
- 5) The image of *B. mori* is focused in each unit ommatidium compositing totally a mosaic image not to form a superposition image interpreted by EXNER.
- 6) The compound eye of *B. mori* is recognized to have more reduced function than that of *B. mandarina*.

LITERATURE CITED

- AINO, Y. : Morphological studies on the compound eye of the dragonfly, *Anax parthenope* SELYS., I (in Japanese); *Oyōdōbutsu*, 5(6): 269—276 (1933)
- : Morphological studies on the compound eye of the dragonfly, II (in Japanese); *ibid.*, 6(2): 51—64 (1934)
- : On the structure of compound eyes of mantis (in Japanese); *ibid.*, 7(1): 1—16 (1935)
- : Morphological studies on the compound eye of the dragonfly, III (in Japanese); *ibid.*, 8(2): 63—71 (1936)
- AST, F. : Über den feineren Bau der Facettenaugen bei Neuropteren; *Zool. Jahrb. Anat.*, 41: 411—458 (1920)
- BARLOW, H. B. : The size of ommatidia in apposition eyes; *Jour. Expt. Biol.*, 29(4): 667—674 (1952)
- BECKING, L. B. & J. C. CHAMBERLIN : A note on the refractive index of chitin; *Proc. Soc. Expt. Biol. & Med.*, 22: 256 (1925)
- BEDAU, K. : Das Facettenauge der Wasserwanzen; *Zeit. wiss. Zool.*, 97: 417—456 (1911)
- BELING, J. : Über das Zeitgedächtniss der Bienen; *Zeit. vergl. Physiol.*, 9: 259—338 (1929)
- BENNITT, R. : The migration of the retinal pigment in Crustaceans; *Jour. Expt. Zool.*, 40: 381—435 (1924)
- : Diurnal rhythm in the proximal pigment cells of crayfish retina; *Physiol. Zool.*, 5: 65—69 (1932)
- , A. D. MERRICK : Migration of the proximal retinal pigment in the crayfish in relation to oxygen deficiency; *Biol. Bull. Mar. Biol. Labor. Wood's Hole*, 62: 168—177 (1932)
- BERNHARDS, H. : Der Bau des Komplexauges von *Astacus fluviatilis* (*Potamobius astacus* L.); *Zeit. wiss. Zool.*, 116: 649—707 (1916)

- BOHN, G. : La persistance du rythme des marées chez l'Actinia equina; Compt. rend. Soc. Biol., ann. 1906, 2: 661—663 (1906)
- : Les rythmes vitaux chez les Actinies; Compt. rend. Franç. Av. Sci., 37: 613—619 (1909)
- BUGNION, F. & N. POPOFF : Les yeux des insectes nocturnes; Arch. d' Anat. micros., 16 (1914)
- BÜNNING, E. : Zur Kenntnis des endonomen Tagesrhythms bei Insekten und bei Pflanzen; Ber. d. deuts. Bot. Gesell., 53: 594—623 (1935)
- CASTEL, E. S. : The interrelation of the eyes of palaemonetes as concerns retinal pigment migration; Proc. Nat. Acad. Sci. U. S. A., 13: 637—639 (1927)
- CLAPARÈDE, E. : Zur Morphologie der zusammengesetzten Augen bei den Arthropoden; Zeit. wiss. Zool., 10: 191—214 (1860)
- COLLINS, D. L. : Iris pigment migration and its relation to behavior in the codling moth; Jour. Expt. Zool., 69: 165—185 (1934)
- CONGDON, : The effect of temperature on the migration of the retinal pigment in decapod crustaceans; Jour. Expt. Zool. 4: 539—548 (1907)
- DAY, M. F. : Pigment migration in the eye of the moth, *Ephesia kuehniella* ZELLER; Biol. Bull., 80: 275—291 (1941)
- DEMOLL, R. : Über eine lichtzersetzliche Substanz im Facettenauge, sowie über eine Pigmentwanderung im Appositionsauge; Arch. ges. Physiol., 129: 461—475 (1909)
- : Die Physiologie des Facettenauges; Erg. Zool., 2: 451—516 (1910)
- : Über die Wanderung des Irispigments im Facettenauge; Zool. Jb. Abt. Allg. Zool. & Physiol., 30: 169—180 (1911)
- : Die Sinnesorgane der Arthropoden, ihr Bau und ihre Funktion: 1—243 (1917)
- DETHIER, V. G. : The dioptric apparatus of lateral ocelli, II. Visual capacities of the ocellus; Jour. Cell. and Comp. Physiol., 22 (2): 115—126 (1943)
- : Vision (Insect physiology): 488—522 (1953)
- DIETRICH, W. : Über Doppelaugen bei Dipteren; Zool. Anz., 32 (1907)
- ELTRINGHAM, H. : Butterfly vision; Trans. Ent. Soc. London, 1.2 (B): 1—4 (1919)
- EXNER, S. : Die Physiologie der facettierten Augen von Krebsen und Insekten: 1—206 (1891)
- VON FRISCH, K. : Studien über die Pigmentverschiebung im Facettenauge; Biol. Zbl., 28: 662—671, 698—704 (1908)
- FRIZA, F. : Zur Frage der Färbung und Zeichnung des facettierten Insektenauges; Zeit. vergl. Phys. 8 (1928)
- GRENÄCHER, H. : Zur Morphologie und Physiologie des facettierten Arthropodenauges; Nachr. Ges. Wiss., Göttingen (1875)
- : Untersuchungen über das Arthropodenauge; Beil. Klin. Monatsbl. f. Augenheilk., Jahrg., 15 (1877)
- : Untersuchungen über das Sehorgan der Arthropoden, insbesondere der Spinnen, Insekten und Crustaceen: 1—188 (1879)
- GRIFFIN, D. R. & J. H. WELSH : Activity rhythms in bats under constant external conditions; Jour. Mammal., 18: 337—342 (1937)

- GUNN, D. L. : The daily rhythm of the cockroach, *Blatta orientalis* L., I. Aktograph experiments, especially in relation to light; Jour. Expt. Biol., 17 (3): 267—277 (1940)
- HANSTRÖM, B. : Vermischte Beobachtungen über die chromatophorenaktivierenden Substanzen der Augentiele der Crustaceen und des Kopfes des Insekten; Lunds Univ. Arsskrift, N. F., 32 (1937 a)
- : Inkretorische Organe und Hormonfunktionen bei den Wirbellosen; Erg. Biol., Bd. 14: 143—224 (1937 b)
- : Hormones in invertebrates: 1—198, Oxford (1939)
- HARIZUKA, M. : On the second spiracle on the thoracic segment in the silkworm moth (in Japanese); Jour. Seric. Scie. Jap., 16 (1.2): 46—47 (1901)
- HENKE, S. H. E. : Retinomotor and diurnal rhythm in crustaceans; Jour. Expt. Biol., 29: 178—191 (1952)
- HESSE, R. : Über die sogenannten einfachen Augen der Insekten; Vorl. Mitteil. Zool. Anz., 24 (1901 a)
- : Untersuchungen über die Organe der Lichempfindung bei niederen Tieren, VII; Zeit. wiss. Zool., 70: 347—473 (1901 b): VIII; *ibid.*, 72: 565—656 (1902)
- : Das Sehen der niederen Tiere; Jena, Fischer (1908)
- HICKSON, S. J. : The eye and optic tract of insects; Quart. Jour. Micro. Sci., 2 (25): 215—221 (1885)
- HOGBEN & SLOME, : The pigmentary effector system VI.; Proc. Roy. Soc. Lond. B., 108: 10—53 (1931)
- HOLMQUIST, A. G. : Beiträge Zur Kenntnis der 24-stündigen Rhythmik der Leber; Z. mikrosk. anat., Forsch., 25: 30—43 (1931)
- IKEDA, A. : Metamorphosis of the nervous system in the silkworm (in Japanese); Sangyō Shinpō, 141: 858—861 (1904)
- : Anatomy and physiology of the silkworm: (in Japanese) 663—666 (1913)
- IMMS, A. D. : The compound eye (A general text book of entomology): 72—81 (1930)
- ISHIHARA, T. : Observation on the hybrid between *Bombyx mori* and *B. mori mandarina* (in Japanese); Konchūkai, 9 (83): 1—8 (1941)
- : Ecology of *Bombyx mori mandarina* and its relation to *B. mori* (in Japanese); Takarazuka kanpō, 31: 1—22 (1943)
- JOHANSEN, J. : Die Entwicklung des Imagoauges von *Vanessa urticae* L.; Zool. Jahrb. Anat., 6: 445—480 (1893)
- JOHNAS, W. : Das Facettenauge der Lepidopteren; Zeit. wiss. Zool., 97: 218—261 (1911)
- JOHNSON, M. S. : Effect of continuous light or periodic spontaneous activity of white footed mice (*Peromyscus*); Jour. Expt. Zool., 82: 315—323 (1939)
- KALMUS, H. : Tagesperiodisch verlaufende Vorgänge an der Staubheuschrecke (*Dixippus morosus*) und ihre experimentelle Beeinflussung; Zeit. vergl. Physiol., 25: 494—508 (1938 a)
- : Das Aktogramm des Flusskrebsses und seine Beeinflussung durch Organextrakte; Zeit. vergl. Physiol., 25: 798—802 (1938 b)
- KATO, M. : Biosynthesis of nicotinamide from 3-hydroxykynurenine in the "White-1" mutant type of silkworm (in Japanese); Physiol. & Ecol., 4 (3.4): 44—45 (1951)
- KATSUNO, S. : Histological observation on the ganglion in the silkworm;

Lectured in Tōhoku sanshi gakkai (1953)

- KAWAGUCHI, E. : Consideration on the affinity between *B. mori* and *B. mandarina* from cytological point of view (in Japanese); Sangyo Shinpō, 358: 46—52, 359: 159—165, 361: 428—434 (1923 a)
- : Cytological study on the hybrid between *Bombyx mori* and *B. mandarina* (preliminary report, in Japanese); Jap. Zool. Mag., 35 (417—422): 427—429 (1923 b)
- : Zitologische Untersuchungen am Seidenspinner und seinen Verwandten; Zeit. f. Zell. & mikros. Anat., 7 (4): 519—552 (1928)
- : Chromosome analysis of the wild silkworm by crossing with the domestic silkworm (in Japanese); Jap. Jour. Gen., 9 (3): 154—156 (1934)
- , J. KON : Hormonous substance relating to the development of the pigment in the compound eye and egg of silkworm (in Japanese); Sapporo Nōringaku Kaihō, 104: 336—337 (1937)
- : Gonadentransplantation bei *Bombyx mori* und Imaginalaugen-sowie Eierpigmentierung durch die Implantate; Plant & Anim., 6 (6): 9—19 (1938)
- KAWASE, S. & H. ARUGA : Biochemical genetics on the pigment of the egg and compound eye in the silkworm (in Japanese); Jap. Jour. Gen., 28 (4) 170—171 (1953)
- KE, O. : Prothoracic gland in the domesticated and wild silkworm (in Japanese); Bult. Sci. Fakul. Terkul., Kjusū Imp. Univ., 4 (1): 12—21 (1930 a)
- : Grain body on the brain in larva and pupa of *Bombycidae* (in Japanese); ibid., 4 (1): 37—44 (1930 b)
- KIESEL, A. : Untersuchungen zur Physiologie des facettierten Auges; Sitzgs. ber. Akad. Wiss. Wien, Math.-naturwiss. kl., 103 (3): 97—139 (1894)
- KIKKAWA, H. : Studies on the relation between the eye-color and the egg-color of a silkworm by means of ovarian transplantation; Jap. Zool. Mag., 49 (10): 348—353 (1937)
- : Studies on the gene-hormones in *Bombyx mori*, I. The v^+ -substance; ibid., 52 (5): 191—199 (1940)
- : Mechanism of pigment formation in the eyes and eggs of insects (*Bombyx* and *Drosophila*) (in Japanese); Jap. Zool. Mag., 53 (6): 310 (1941 a)
- : Studies on the color substances found in *Bombyx* and *Drosophila* (A preliminary note); Jap. Zool. Mag., 53 (10): 507—509 (1941 b)
- : The origin of pigments in insects and the role of genes (in Japanese); Jap. Jour. Gen., 18 (2): 87—88 (1942)
- : Problems on tryptophan metabolism in insects; Kagaku, 13 (8): 282—285, 13 (9): 319—325 (1943)
- : Pigment of tryptophane group in the silkworm (in Japanese); Progress in Biol., Ser. 3, 36—70 (1948)
- : Genetics and biochemistry (in Japanese); Kagaku no Ryōiki, 3 (1949)
- KIRCHHOFFER, O. : Untersuchungen über die Augen pentamerer Käfer; Arch. Biontol, 2: 235—287 (1908)
- KLEINHOLZ, L. H. : Eye-stalk hormone and the movement of distal retinal pigment in Palaemonetes; Proc. Nat. Acad. Sci., 20: 659—661 (1934)
- : Crustacean eye-stalk hormone and retinal pigment migration; Biol. Bull.,

- 70: 159—184 (1936)
- : Studies on the pigmentary system of the retinal pigments of Bermudan decapods; Biol. Bull., 72: 176—189 (1937)
- : Factors controlling the migration of the proximal pigment of the crustacean retina; Anat. Rec., 101: 15 (1948)
- : Migrations of the retinal pigments and their regulation by the sinus gland; Bull. Biol. Fr. e. Belg. Suppl., 33 (1949 a)
- : Responses of the proximal retinal pigment of the isolated crustacean eye-stalk to light and darkness; Proc. Nat. Acad. Sci., 35: 215—218 (1949 b)
- . F. G. KNOWLES : Studies in the pigment system of crustacea, III. Light intensity and retinal pigment migration; Biol. Bull., 75: 266—273 (1938)
- KLEITMAN, : Biological rhythms and cycles; Physiol. Rev., 29: 1—30 (1949)
- KOPÉČ, S. : Mutual relationship in the development of the brain and eyes of Lepidoptera; Jour. Expt. Zool., 36: 459—466 (1922)
- KOYAMA, N. : A preliminary note on the compound eye of the mole cricket, *Gryllotalpa africana* PAUSOT et BEAUVOIS; Jour. New. Ent., 2 (3.4): 5—6 (1952 a)
- : A preliminary note on the compound eyes of Bombycid and Saturnian moths; Res. Rep. Facul. Text. & Seric., Shinshu Univ., 2: 47—50 (1952 b)
- : The reticular pigment migration in the compound eye of the Eri-silk-worm moth (in Japanese); Sanshi, Chūbushibu, Ser., 5: 28 (1953 a)
- : The imaginal compound eye developed on the abdomen of the silkworm moth after transplantation of the larval optic discs (in Japanese); Res. Rep. Facul. Text. & Seric., Shinshu Univ., 3: 44—47 (1953 b)
- KUWANA, J. : Degeneration of muscles in the silkworm moth (in Japanese); Jap. Zool. Mag., 48 (8—10): 881—884 (1936)
- LEECH, J. H. : Lepidoptera of Japan and Corea; Proc. Zool. Soc. London, 1888, 626: 222 (1888)
- : Lepidoptera Heterocera from North China, Japan and Corea; Trans. Ent. Soc. London, 271; 22 (1898)
- LEYDIG, F. : Das Auge der Gliedertiere, Neue Untersuchungen zur Kenntnis dieses Organs: 1—50 (1864)
- : (1868); Cited from AINO (1935)
- LUBBOCK, J. : On the senses, instincts, and intelligence of animals, with special reference to insects; London: 1—292 (1888)
- MENKE, H. : Perisdische Bewegungen und ihre Zusammenhang mit Licht und Stoffwechsel; Plug. Arch. ges. Physiol., 14: 37 (1911)
- MERKER, E. : Einfache Praktikumversuche zur Beobachtung der Pigmentwanderung in den Augen von Tagfaltern und Dämmerungschmetterlingen; Biol. Zbl., 49: 186—191 (1929)
- MORI, S. : Daily rhythmic activity of the sea-pen, *Cavernularia obesa* VALENCIENNES, I. Observation in the natural condition (in Japanese); Jap. Zool. Mag., 55 (7): 247—253 (1943 a)
- : Daily rhythmic activity of the sea-pen, *Cavernularia obesa* VALENCIENNES, II. Activity in the continuous light and darkness (in Japanese); Jap. Zool. Mag., 55 (8): 285—291 (1943 b)
- : Daily rhythmic activity of the sea-pen, *Cavernularia obesa* VALENCIENNES,

- III. Controlling of the activity by light (in Japanese); Jap. Zool. Mag., 56 (1) : 1—5 (1944 a)
- : Daily rhythmic activity of the sea-pen, *Cavernularia obesa* VALENCIENNES, VI. Analysis of intrinsic rhythmicity (in Japanese); Jap. Zool. Mag., 56 (2) : 16—20 (1944 b)
- : General consideration on relations between behavior rhythm of animals and environmental rhythm (in Japanese); Rep. Physiol. & Ecol., Kyōto Univ., 39 (1945 a)
- : Daily rhythmic activity of the sea-pen, *Cavernularia obesa* VALENCIENNES, VIII. Endogenous daily rhythmic activity; *ibid.*, 19 (1945 b)
- : Daily rhythmic activities of the Japanese fresh water snails (1); *ibid.*, 60 (1946)
- : A concept on mechanisms of the endogenous daily rhythmic activity; Mem. Coll. Sci. Univ. Kyōto, Ser. B., 19 : 1—4 (1947 a)
- : Daily rhythmic activity of the sea-pen, *Cavernularia obesa* VALENCIENNES, IX. Activity under constant darkness during 103 days (in Japanese); Physiol. & Ecol., 1 (1) : 8—14 (1947 b)
- : Harmony between behavior rhythm and environmental rhythm; *ibid.*, 19 : 71—74 (1948 a)
- : Daily rhythmic activity of the sea-pen, *Cavernularia obesa* VALENCIENNES, X. Two kinds of stimulus which control the activity; Physiol. & Ecol., 2 (1) : 34—38 (1948 b)
- : Daily rhythmic activities of the Japanese freshwater snails (2); Seibutu, 8 : 204—209 (1948 c)
- : Rhythmic activities of animals (in Japanese); Hoppō Syuppan Sya (1948 d)
- : Daily rhythmic activity of the sea-pen, *Cavernularia obesa* VALENCIENNES, XII. Conclusions—Problems on relations among environments, behaviors and internal physiological conditions; Physiol. & Ecol., 4 (1.2) : 12—20 (1950)
- : Relation between activity and glycogen contents of the Japanese loach; Mem. Coll. Sci., Univ. Kyōto, Ser. B. 20 : 1—6 (1951)
- . K. MATUTANI : Studies on the daily rhythmic activity of the starfish, *Astropecten polyacanthus* MÜLLER et TROSCHEL, and the accompanied physiological rhythms; Publ. Seto Mar. Biol. Lab., 2 (2) : 213—225 (1952)
- MOROHOSHI, S. : Transplantation of optic discs and eye colours in *Bombyx mori*, I. (in Japanese); Jap. Jour. Gen., 14 (5) : 204—210 (1938)
- : Transplantation of optic discs and eye colours in *Bombyx mori*, II. (in Japanese); *ibid.*, 17 (1) : 21—27 (1941)
- MOSSLER, A. : Die Pigmentwanderung im Auge von *Palaemon squilla*; Dendschr. Akad. wiss. Wien, Math-naturwiss. Kl., 91 : 579—608 (1915)
- MÜLLER, J. : Zur vergleichenden Physiologie des Gesichtsinnes der Menschen und der Tiere : 1—462 (1826)
- : Fortgesetzte anatomische Untersuchungen über den Bau der Augen bei den Insekten und bei den Crustacean; Arch. Anat. Physiol. 507 (1829)
- NAGANO, T. : Studies on the diurnal rhythm of the eye of the shrimps (prelim. rep.) (in Japanese); Bull. Jap. Soc. Sci. Fisheries, 11 : 163—167 (1943)
- : Physiological studies on the pigmentary system of crustacea, II. The

- pigment migration in the eyes of the shrimps; Sci. Rep. Tōhoku Univ. Ser. IV, 18 (1): 65—80 (1947)
- : Physiological studies on the pigmentary system of crustacea, IV. Studies on the diurnal rhythm of the eye pigments of the shrimps; *ibid.*, 18 (3): 286—297 (1950)
- : Physiological studies on the pigmentary system of crustacea, IX. An analysis of the behavior of the proximal retinal pigment in the shrimp; *ibid.*, 19 (3): 219—220 (1952)
- NOWIKOFF, M. : Untersuchungen über die Komplexaugen von Lepidopteren nebst einigen Bemerkungen über die Rhabdome der Arthropoden im allgemeinen; Zeit. wiss. Zool., 138: 1—67 (1931)
- OGUMA, K. : A histological study on compound eyes of the dragonfly (in Japanese); Jap. Ent. Mag., 3: 101—121 (1917)
- OKA, A. : Structure and function of compound eye (in Japanese); Jap. Zool. Mag., 11 (126): 123—128 (1899)
- OMURA, S. : Spermatozoa of *Lepidoptera*, I. Specific differentiation in the spermatoprostic reaction (in Japanese); Jap. Jour. Gen., 15 (3): 148—152 (1939)
- : Spermatozoa of *Lepidoptera*, III. Spiral coiling of the bundle of spermatozoa (in Japanese); *ibid.*, 17 (6): 295—303 (1941)
- : Behavior and cocoon of *Bombyx mandarina*; Sci. Rep. Seric. Expt. Stat. 13 (3): 79—130 (1950)
- OHSAWA, W., MATUTANI, K., TUKUDA, H., MORI, S., MIYADI, D., YANAGISIMA, S. & Y. SATO : Sexual properties of the daily rhythmic activity in *Drosophila melanogaster* (in Japanese); Physiol. & Ecol., 5 (1.2): 26—30 (1952)
- PACKARD, A. S. : The sensory organs (A text book of entomology); 249—264 (1898)
- PARK, O. : Nocturnalism—The development of a problem; Ecol. Monogr., 10: 485—536 (1940)
- : J. G. KELLER : Studies in nocturnal ecology, II. Preliminary analysis of activity rhythm in nocturnal forest insects; Ecol. 13: 335—346 (1932)
- PARKER, G. H. : Photomechanical changes in the retinal pigment cells of *Palaemonetes*, and their relation to the central nervous system; Bull. Mus. Comp. Zool., 30 (6): 273—300 (1897)
- : Actinian behavior; Jour. Expt. Zool., 22: 193—229 (1917)
- : The movements of the retinal pigment; *Ergeb. Biol.*, 9: 239—291 (1932)
- PHYLLIPS, E. F. : Structure and development of the compound eye of the honey bee; Proc. Acad. Nat. Sci., Philadelphia, 57: 123—157 (1905)
- PIERON, H. : Des rythmes engendrés par une variation périodique de la teneur en oxygène; Compt. rend. Soc. Biol., ann. 1908, 1: 1020—1022 (1908)
- PRYER, H. : A catalogue of the *Lepidoptera* of Japan (2); Trans. Asiat. Soc. Japan, 12 (2): 54 (1884)
- RAMSAY, J. A. : A Physiological approach to the lower animals: 1—148 (1952)
- ROSENSTADT, B. : Beiträge zur Kenntnis der Baues der zusammengesetzten

- Augne bei den Dekapoden; Arch. mikr. Anat., 47: 748—770 (1896)
- SASAKI, C. : On the affinity of our wild and domestic silkworm; Ann. Zool. Jap., 2: 33—40 (1898)
- SATO, S. : Compound eyes of *Culex pipiens* var. *pallens* COQUILLET (Morphological studies on the compound eye in the mosquito, I); Sci. Rep. Tôhoku Univ., Biol., 18 (3): 331—341 (1950)
- : Structure and development of the compound eye of *Aedes (Finlaya) japonicus* THEOBALD (Morphological studies on the compound eye in the mosquito, III); *ibid.*, 20 (1): 33—44 (1953 a)
- : Structure and development of the compound eye of *Anopheles hyrcanus sinensis* WIEDEMANN (Morphological studies on the compound eye in the mosquito, IV); *ibid.*, 20 (1): 45—53 (1953 b)
- SCHULTZE, M. : Untersuchungen über die zusammengesetzten Augen der Krebse und Insekten; Bonn (1868)
- SMITH, R. I. : Studies on the effects of eyestalk removal upon young crayfish (*Cambarus clarkii* GIRARD); Biol. Bull., 79 (1940)
- : The role of the sinus glands in retinal pigment migration in Grapsoid crabs; Biol. Bull., 95: 169—185 (1948)
- SNODGRASS, R. E. : Principles of insect morphology (1935)
- SUGIYAMA, S. : On the structure of compound eyes in the riceborer moth, *Chilo simplex* BUTLER (in Japanese) Oyôdôbutsu, 5 (5): 211—217 (1933)
- SUZUKI, K. : Genetical research on the colouration of egg and compound eye in the silkworm (in Japanese); Sci. Rep. Seric. Expt. Stat., 11 (2): 125—196 (1943)
- SZYMANSKI, J. S. : Aktivität und Ruhe bei Tieren und Menschen; Z. allg. Physiol., 18: 105—162 (1920)
- TAKEDA, H. : Studies on the periodical secretion of the alluring substances of the Eri-silkworm moth, I (in Japanese); Jap. Ent. Mag., 18 (6): 6—7 (1950): II (in Japanese); Res. Rep. Facul. Text. & Seric., Shinshu Univ., 1: 21—28 (1951): III (in Japanese); *ibid.*, 2: 34—39 (1952): IV (in Japanese); Oyôdôbutsu, 18 (3): 145—148 (1953 a): V (in Japanese); Res. Rep. Facul. Text. & Seric., Shinshu Univ., 3: 35—39 (1953 b): VI (lectured, 1953 c): VII (lectured, 1953 d)
- : Studies on the alluring substances of the domesticated and wild silkworms, I. Identification of the alluring substance in the domesticated silkworm by paperchromatography (in Japanese); Jour. Seric. Scie. Jap. 22 (3): 124—125 (1953 e)
- : Alluring substances in the Bombycid and Saturnian moths; Shinkonchu, 7 (1): 2—4 (1954)
- & K. TANAKA : Secretion of the alluring substance of the silkworm moth in the continuous light and darkness (in Japanese); Jour. Seric. Scie. Jap. 21 (23): 127—128 (1952)
- TANAKA, Y. : A text book of sericulture (in Japanese); Shôkabô (1943)
- TAZIMA, Y. : A case of the mosaicism in the silkworm egg, probably due to a recessive mutation (in Japanese); Jap. Jour. Gen., 18 (6): 305—308 (1942)
- TOYAMA, K. & S. ISHIWATA : Anatomical experiment on silkworm (In Japanese) (1899)

- TROJAN, E. : Das Auge von *Palaemon squilla*; Denkschr. Akad. wiss. Wien, Math.-naturwiss. Kl., 88: 291—344 (1913)
- UCHIDA, H. : Color changes in the eye of a long-horned grasshopper, *Homorocoryphus lineosus*, in relation to light; Jour. Fac. Sci. Imp. Univ. Tokyo, 3: 517—525 (1934)
- UDA, H. : Genetical study on the eye colour of silkworm, I (in Japanese); Sci. Rep. Coll. Agric. Mie, 1: 1—30 (1928)
- : Genetical study on the eye colour of silkworm, II; Jap. Jour. Gen., 6: 145—146 (1930)
- : The eye-color of the silkworm moth (in Japanese); Gakujitsu Kyokai, 7: 137—140 (1932)
- UMBACH, W. : Entwicklung und Bau des Komplexauges der Mehlmotte *Ephestia köhniella* Zeller nebst einigen Bemerkungen über die Entstehung der optischen Ganglien; Zeit. Morph. Ökol. Tiere., 28: 561—594 (1934)
- UMEYA, Y. : A consideration on the function causes the colouration of the eye and egg in the silkworm (Prelim. note, in Japanese); Jap. Jour. Gen., 14 (6): 278—282 (1938)
- VIALLANES, H. : Sur la structure interne du ganglion optique de quelques larves de Diptères; Bull. Soc. Phil., Paris, 7 (9): 75—78 (1885)
- : La structure du cerveau des Hyménoptères; *ibid.*, 7 (10): 82—83 (1886 a)
- : La structure du cerveau des Orthoptères; *ibid.*, 7 (11): 119—126 (1886 b)
- : Sur la morphologie comparée du cerveau des Insectes et des Crustacés; Compt. rend. Acad. Sci. Paris, 54: 444—447 (1887)
- WAGNER, H. O. : Über Jahres-und Tagesrhythmus bei Zugvögeln; Zeit. vergl. Physiol., 12: 703—724 (1930)
- WATASE, S. : On the morphology of compound eyes of Arthropods; Stud. Biol. Lab. Johns. Hop. Univ., 4 (6) (1890)
- WEBER, H. : Lehrbuch der Entomologie; Jena (1933)
- WELSH, J. H. : The mechanics of migration of the distal pigment cells in the eyes of *Palaemonetes*; Jour. Expt. Zool., 56: 459—494 (1930 a)
- : Diurnal rhythm of the distal pigment cells in the eyes of certain crustaceans; Proc. nat. Acad. Sci., U.S.A., 16: 386—395 (1930 b)
- : The nature and movement of the reflecting pigment in the eyes of crustaceans; Jour. Expt. Zool., 62: 173—183 (1932)
- : Further evidence of a diurnal rhythm in the movement of pigment cells in eyes of crustaceans; Biol. Bull., 68: 247—253 (1935)
- : Diurnal rhythms; Quart. Rev. Biol. 13 (1938)
- : The action of eye-stalk extracts on retinal pigment migration in the crayfish, *Cambarus bartoni*; Biol. Bull., 77: 119—125 (1939)
- : The sinus gland and 24-hours cycles of retinal pigment migration in the crayfish; Jour. Expt. Zool., 96 (1941)
- : New evidence concerning the source and action of the eyestalk hormone; Anat. Rec. 111 (1951)
- WIGGLESWORTH, : The principle of insect physiology (1950), London
- WOLF, E. : Die Aktivität der japanischen Tanzmaus und ihre rhythmische Verteilung; Zeit. vergl. Physiol., 11: 321—344 (1930)
- WOLSKY, A. : The growth and differentiation of reticular cells in the

- compound eyes of the silkworm (*Bombyx mori* L.); Expt. Cell. Res. Suppl., 1: 549—554 (1949)
- YAGI, N. : Preliminary report on the hybrid between *Bombyx mori* × *B. mandarina* (in Japanese); Jap. Zool. Mag., 34 (408): 832—834 (1922)
- : On the structure and dioptrics of compound eye of *Chilo simplex* BUTLER (in Japanese); Jour. Imp. Agric. Expt. Stat., 3 (2): 183—206 (1938)
- : On the compound eye of Hesperiid butterflies; Jap. Ent. Mag., 18 (5): 32—36 (1950)
- : Studies on the compound eyes of Lepidoptera, 1. On the compound eyes of butterflies, especially on the pseudopupil and its meaning to the phylogeny of species; Jour. Shinshu Univ., 1: 131—173 (1951)
- : Brief note on the compound eye of a Scarabaeid beetle, *Copris ochus* MOTSCHULSKY; Jour. New. Ent., 2 (1.2): 8—11 (1952 a)
- : Examples of evolution of the compound eye concerning the superposition and the apposition types; Jour. New. Ent., 2 (3.4): 1—4 (1952 b)
- : The taxonomic position of the HesperIIDae as derived from the morphology of the compound eye; Trans. 9th. Int. Congr. Ent., 1: 76—78 (1952 c)
- : Studies on the compound eyes of Lepidoptera, 2. On the morphology and function of the compound eyes of *HesperIIDae*; Jour. Shinshu Univ., 3: 29—41 (1953)
- YAMANOUCHI, T. : Ecological and physiological studies on the holothurians in the coral reef of Palao Islands; Palao Trop. Biol. Stat. Stud., 1: 603—635 (1939)
- ZIMMER, C. : Die Facettenaugen der Ephemeriden; Zeit. wiss. Zool., 63: 236—262 (1898)
- ZIMMERMANN, K. : Über die Facettenaugen der Libelluliden, Phasmiden, und Mantiden; Zool. Jahrb., Anat. Ont., 37: 1—36 (1914)

EXPLANATION OF THE PHOTOS

PLATE I (*B. mori*)

- Photo 1. Image of a butterfly formed behind the cornea, ×350
- Photo 2. Compound eye of the white-eye mutant, ×12
- Photo 3. Longitudinal section of the crystalline part in the dark adapted eye (stained), ×310
- Photo 4. Image of a human hand formed behind the crystalline cone, ×700
- Photo 5. Chitinous ring supporting the whole mass of the ommatidia, ×15
- Photo 6. Longitudinal section of the reticular part in the light adapted eye (stained), ×330
- Photo 7. Single crystalline cone (stained), ×700
- Photo 8. Single ommatidium, showing especially the rhabdome connection.
- Photo 9. Tracheal tapetum, ×520

PLATE II (*B. mori*)

- Photo 10. Corneal facet, ×350

- Photo 11. Semper's cell observed through the cornea, $\times 350$
 Photo 12. Cross section of the crystalline cone in the dark adapted eye, $\times 350$
 Photo 13. Ditto (stained), $\times 350$
 Photo 14. Cross section of the distal layer of the reticular pigment cell in the light adapted eye, $\times 350$
 Photo 15. Ditto of the reticular layer under the crystalline cone in the light adapted eye (stained), $\times 400$
 Photo 16. Ditto of the middle layer of the reticular pigment cell in the dark adapted eye (stained), $\times 400$
 Photo 17. Single point of light focused behind the detached cornea, $\times 350$

PLATE III (*B. mori*)

- Photo 18. Cross section of the reticular nucleus (stained), $\times 500$
 Photo 19. Ditto of the middle layer of the rhabdomere (stained), $\times 1000$
 Photo 20. Ditto of the proximal layer of the rhabdomere (stained), $\times 1000$
 Photo 21. Ditto of the rhabdome nucleus (stained), $\times 700$
 Photo 22. Ditto of the nuclear layer of the basal pigment cell (stained), $\times 230$
 Photo 23. Ditto of the periopticon, where the compound bundle nerve cord is connected, $\times 300$
 Photo 24. Longitudinal section of the periopticon (stained), $\times 400$
 Photo 25. Ditto of the optic lobe (stained), $\times 250$

PLATE IV (*B. mori*)

Downward migration of the pigment in the eye of Japanese race when exposed to the light (2kilo-lux), Photo 26~31. $\times 300$

- Photo 26. 2' exposure,
 Photo 27. 5' exposure,
 Photo 28. 10' exposure,
 Photo 29. 20' exposure,
 Photo 30. 30' exposure,
 Photo 31. Completely light adapted, $\times 110$
 Photo 32. Light adapted eye of Fujiiroran (longitudinal section), $\times 140$

PLATE V

- Photo 33. Longitudinal section of the proximal part of *B. mori* eye (stained after depigmentation), $\times 500$
 Photo 34. Basal pigment in the normal (black) eye of *B. mori*, $\times 500$
 Photo 35. Ditto in the eye of Fujiiroran, $\times 500$
 Photo 36. Ditto in the dark adapted eye of *B. mandarina*, $\times 500$
 Photo 37. Reflective substance which covers the cone body in the eye of Japanese bivoltine \times Chinese bivoltine (in dark field), $\times 260$
 Photo 38. Ditto in the eye of European race (Zebra), $\times 300$
 Photo 39. Ditto in the above hybrid eye, showing by the cross section, $\times 150$
 Photo 40. Ditto in the eye of *B. mandarina*, $\times 90$

PLATE VI (*B. mori*)

- Photo 41. Light adapted eye of the red-eye mutant (longitudinal section), $\times 37$
 Photo 42. Ditto of the yellow-eye mutant (longitudinal section), $\times 370$
 Photo 43. Dark adapted eye of ω_2 -mutant (longitudinal section), $\times 40$
 Photo 44. Tracheal branch in the compound bundle layer of the nerve cord, $\times 700$
 Photo 45. Dark adapted eye of the red-eye mutant (longitudinal section), $\times 37$
 Photo 46. Ditto of the yellow-eye mutant (longitudinal section), $\times 370$
 Photo 47. Ditto of ω_2 -mutant (longitudinal section), $\times 370$
 Photo 48. Tracheole bush distributed at the part of the ocellus remnant in the optic lobe, $\times 1000$

PLATE VII

- Photo 49. Longitudinal section of the crystalline part in *B. mandarina* (light adapted), $\times 600$
 Photo 50. Cross section of the retinular pigment layer in *B. mandarina* (light adapted), $\times 1000$
 Photo 51. Longitudinal section of the proximal part of the eye in *B. mandarina* (stained), $\times 230$
 Photo 52. Ditto of the crystalline part in *B. mandarina* \times *B. mori* (half light adapted), $\times 400$
 Photo 53. Ditto in cross section, $\times 400$
 Photo 54. Tracheoles expanding to the crystalline cone in *B. mori* (stained), $\times 950$
 Photo 55. Reflective substance discovered in the ocellus remnant of *B. mori* (in dark field), $\times 1200$
 Photo 56. Retinular nuclei and tracheoles in *B. mori* eye (stained), $\times 950$
 Photo 57. Longitudinal section of the proximal part of ω_1 -mutant eye in *B. mori* (stained), $\times 300$
 Photo 58. Iris pigment granules in *B. mori* eye, $\times 1700$

Explanation of abbreviations in the plates

Bm : Basement membrane	Or : Ocellus remnant
Bp : Basal pigment	Po : Periopticon
Bpc : Basal pigment cell	Rd : Rhabdome
Bpn : Nucleus of the basal pigment cell	Rdn : Rhabdome nucleus
Cbl : Compound bundle layer of the nerve cord	Rm : Rhabdomere
Cc : Crystalline cone	Rn : Retinular nucleus
Co : Cornea	Rp : Retinular pigment
Cr : Chitinous ring	Rpc : Retinular pigment cell
Ec : External chiasma	Rpn : Nucleus of the retinular pigment cell
Eo : Epipticon	Rs : Reflective substance
Ic : Iris cell	Sbl : Single bundle layer of the nerve cord
Icn : Iris cell nucleus	Sc : Semper's cell
Ip : Iris pigment	To : Tracheole
Nc : Nerve cord	Tr : Tracheal branch
	Tt : Tracheal tapetum

